



FEATURES

- Available in detachable 7 Pin FUTEK Receptacle and 32 AWG high flex cable
- SPI (Serial Peripheral Interface) - best option for embedded electronics solution
- UART (Universal Asynchronous Receiver/Transmitter) - use for a clean and packaged data stream; ideal for R&D applications
- Up to 15 bits noise-free resolution
- Ultra low power consumption
- High performance tension and compression load cell with $\pm 0.05\%$ nonrepeatability
- Light weight, miniature size
- Integrated overload protection
- Shock resistant
- Mechanical strain relief (UART and/or SPI version)

■ Non-loading surface, do not contact

■ Active End

■ Fixed End

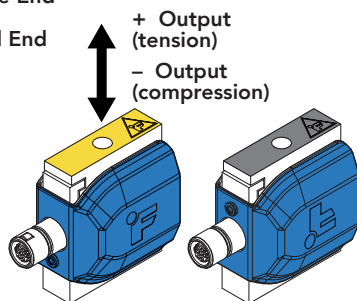

SPECIFICATIONS

PERFORMANCE

Nonlinearity	$\pm 0.1\%$ of Capacity
Hysteresis	$\pm 0.1\%$ of Capacity
Nonrepeatability	$\pm 0.05\%$ of Capacity

ELECTRICAL

Insulation Resistance	≥ 500 MOhm @ 50 VDC
UART only (connector version)	FUTEK 7-Pin Receptacle
SPI and/or UART (cable version)	32 AWG 10 conductor spiral shielded silicone jacket, 6 in [152 mm]

MECHANICAL

Weight (approximate)	0.03 lbs [14.2 g]
Safe Overload	1000% of Capacity (compression: all, tension: 1–25 lb) 200% of Capacity (tension only: 50–100 lb)
Material	17-4 PH stainless-steel body, anodized cover
IP Rating	IP40
Shock Resistance	500 g per IEC60068-2-27

TEMPERATURE

Operating Temperature	-40 to 185°F [-40 to 85°C]
Compensated Temperature	60 to 160°F [15 to 72°C]
Temperature Shift Zero	$\pm 0.005\%$ of Capacity/°F [0.009% of Capacity/°C]
Temperature Shift Span	$\pm 0.005\%$ of Load/°F [0.009% of Load/°C]

LOAD CALIBRATION

Load Calibration (standard)	5-pt Tension
Load Calibration (available)	5-pt Tension and Compression

POWER

Supply	3 VDC to 5 VDC
Power Consumption	78 mW
Inrush Current	180 mA (Max)

OUTPUT

Noise Free Resolution	Up to 15 Bits (See Table)
Sampling Rate	Up to 1,300 SPS
UART	See Table
SPI	See Table

CONFORMITY

RoHS Compliant	2011/65/EU
----------------	------------

DIMENSIONS inches [mm]

TOLERANCE:
 .X ± 0.1" [2.5]
 .XX ± 0.01" [0.25]
 .XXX ± 0.005" [0.127]

SPI AND/OR UART VERSION

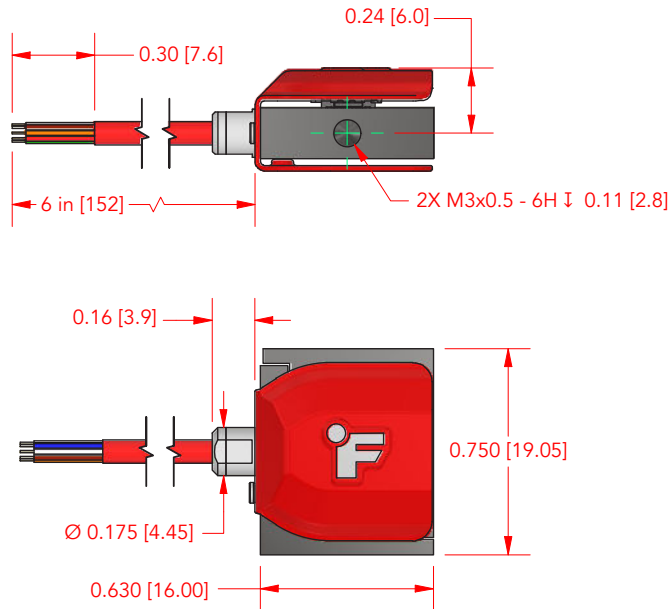

SPI AND/OR UART WIRING CODE

PROTOCOLS	PIN FUNCTION	DESCRIPTION	COLOR CODE
SPI	HICO	Host-In-Client-Out	White
	HOCl	Host-Out-Client-In	Green
	SCLK	Serial Clock	Gray
	$\overline{\text{CS}}$	Chip Select	Blue
	$\overline{\text{DRDY}}$	Data Ready	Yellow
Power	VIN	Voltage Input	Red
	GND	Ground	Black
UART	RX	Receive Signal	Brown
	TX	Transmit Signal	Orange

Note: The following criteria must be met to achieve highest performance

- 20 mV–40 mV peak-to-peak ripple in pass band
- 20 MHz bandwidth (cutoff 40 dB @ 20 MHz)
- Both the SPI and UART outputs in the cable version unit can be used simultaneously

RESOLUTION

Capacity (lb/N)	Noise Free Resolution @ 4 SPS (lb/N)	Back Calculated Value in Bits @ 4 SPS	Noise Free Resolution @ 1300 SPS (lb/N)	Back Calculated Value in Bits @ 1300 SPS	Natural Frequency (Hz)
1 / 4.5	0.00005 / 0.00022	15.0	0.001 / 0.004	10.7	690
2 / 9.0	0.00025 / 0.00111	13.7	0.003 / 0.013	10.1	1180
5 / 22.4	0.001 / 0.004	13.1	0.009 / 0.040	9.8	2180
10 / 44.8	0.0016 / 0.0071	14.3	0.02 / 0.09	9.7	3010
25 / 112	0.004 / 0.0178	13.3	0.05 / 0.22	9.7	5380
50 / 224	0.005 / 0.0223	14.0	0.08 / 0.36	10.0	6620
100 / 448	0.008 / 0.036	14.3	0.2 / 0.89	9.7	8250

DIMENSIONS inches [mm]

TOLERANCE:
 .X ± 0.1" [2.5]
 .XX ± 0.01" [0.25]
 .XXX ± 0.005" [0.127]

UART ONLY VERSION

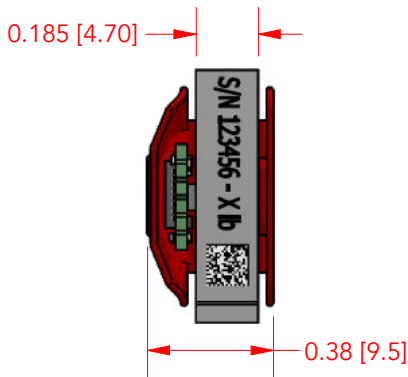
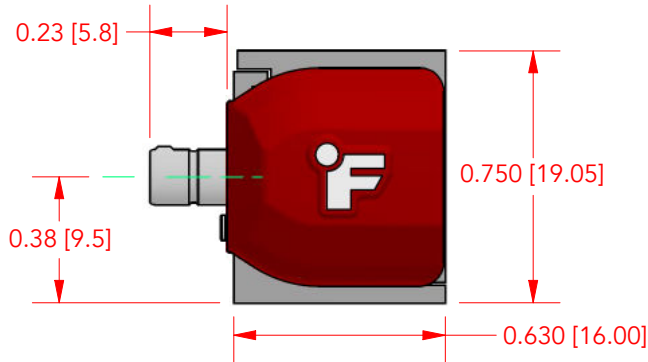

UART ONLY CONNECTOR CODE CC18U

PIN	COLOR	DESCRIPTION
1	Black	Ground
3	Red	Voltage Input
6	Brown	Receive Signal
7	Orange	Transmit Signal

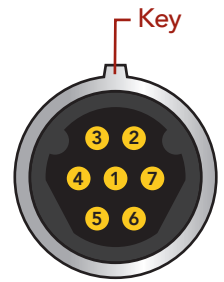

Drawing Number: FI1571

FUTEK reserves the right to modify its design and specifications without notice. Please visit <http://www.futek.com/salesterms> for complete terms and conditions.

The information provided herein was developed using FEA analysis, empirical data and multiple testing simulations. FUTEK presents the information in good faith and believes it is correct but makes no representations or warranties as to the completeness or accuracy of the information provided. User's application may produce different data and/or results. By using this information, you agree that you have read and understand this disclosure. Please contact us to discuss your particular application and needs.

10 Thomas, Irvine, CA 92618 USA
 futek@futek.com

www.futek.com



U.S. Manufacturer