



Series M . M60-LC



Panel meter for load cells

DIGITAL PANEL METERS

Digital panel meter for load cells. Provides excitation voltage to power up to 8 cells. Standard 96 x 48 mm size (1/8 DIN). Reading with 6 digit display. Accepts 4 and 6 wire load cells, includes 'sense' function, fast access to alarm setpoints, tare and 'auto-tare' functions, 'on power up' functions, stability alarms, configurable operator menu, configurable led brightness. Universal AC and DC power. Up to 3 optional modules for output and control (relays, transistor, control SSR, analog outputs, Modbus RTU communications, RS-485 ASCII, RS-232, ...)

www.fema.es

Tel. (+34) 93.729.6004 info@fema.es

1. Panel meter M60-LC

Panel meter for load cells, size 96 x 48 mm (1/8 DIN)

Digital panel meter, with 96 x 48 mm (1/8 DIN) size and 6 digits with 14 mm digit height, for load cell signals. Provides excitation voltage configurable to +5 Vdc or +10 Vdc to power up to 8 standard 350 Ohms cells. Scalable reading from 999999 to -199999 with configurable decimal point.

Tare function, with configurable controls, and 'auto-tare' function for automatic tare correction when weight is removed from the cell. Three working modes with different acquisition speeds and noise rejection to 50 and 60 Hz.

Output and control options with 1, 2 and 3 relays, isolated analog outputs, Modbus RTU communications, transistor outputs, SSR control outputs, RS-485 ASCII and RS-232. Special options up to 4 and 6 relays.

Independent alarms configurable as maximum or minimum, with activation at setpoint or when reading is stable, with 1 or 2 setpoints per alarm, hysteresis, independent activation and deactivation delays, configurable inverted activation of the relay and configurable locked alarms (see section 1.12.8).

Front protection IP65. Connections by plug-in screw terminals. For industrial applications.

Functions included :

- tare accessible from frontal key or rear contact (see section 1.11)
- automatic 'auto-tare' function (see section 1.12.4)
- access to gross weight value and tare value (see section 1.9.5)
- function '**On Power Up**' for automatic activation of functions at start-up (see section 1.12.14)
- scale factor for easy modification of reading units (see section 1.12.5)
- 'stock units' function to count units (see section 1.12.6)
- access to the measured signal value (in mV), excitation current provided (in mA) and real excitation voltage (see section 1.12.13)
- configurable '**Fast access**' menu (key 'UP' (▲)) with access to selected functions (see section 1.12.13)

Multiple display filters, memory for maximum and minimum, password, 5 configurable brightness levels.

1.1 How to use this manual

If this is the first time you are configuring this instrument, below are the steps to follow to install and configure the instrument. Read all the manual sections in order to have a

full and clear view of the characteristics of the instrument. Do not forget to read the installation precautions at section 1.19.

1. Power and signal connections

- connect the power (see section 1.8)
- connect the signal (see section 1.8)
- read recommendations to connect the 'sense' (see section 1.8.1) and for load cell ground connections (see section 1.8.2)

2. Initial setup (see section 1.12.2)

- theoretical configuration of the cell (obtain the load cell data : sensitivity, load and excitation) and configure the instrument
- apply the empirical configuration of the cell (apply the high and low 'field correction')
- assign the 'system zero'

3. Advanced configuration (optional) (see section 1.12.7)

- tare configuration, see sections 1.11 and 1.12.4

- function 'stock units' (see section 1.12.6)

- scale factor (see section 1.12.5)

- acquisition modes (see section 1.9.1)

4. Configure the alarms (optional) (see section 1.12.8)

5. Display filters (optional) (see section 1.12.10)

6. Configure operator controls (optional)

- configure the rear control (see section 1.12.11)
- configure the front key 'LE' (◀) (see section 1.12.12)
- configure the fast access (key 'UP' (▲)) (see section 1.12.13)

7. Configure other functions (optional)

- configure the 'on power up' function (see section 1.12.14)
- configure the password and brightness level (see section 1.12.17)

8. Configure the output and control options: analog (AO) or serial (RTU, S4, S2) (see section 1.12.18)

1.2 Index

1. Panel meter M60-LC	2	1.12.16 'On power up' configuration	19
1.1 How to use this manual	2	1.12.17 Tools	20
1.2 Index	3	1.12.18 Access to options configurations menu	20
1.3 How to order	3	1.13 Full configuration menu	22
1.4 Material included	4	1.14 Factory configuration	25
1.5 Additional information	4	1.15 Messages and errors	25
1.6 Front view	4	1.16 Practical cases	26
1.7 Rear view	4	1.16.1 Normal case	26
1.8 Signal and power connections	5	1.16.2 Load cell with external power.	26
1.8.1 Connecting the 'sense'	5	1.16.3 Connections with a junction box	26
1.8.2 Connecting the cell to the ground	5	1.16.4 Connections with 3 or 4 load cells	27
1.8.3 Real cases	5	1.16.5 Measuring mV at the laboratory	27
1.9 Technical specifications.	6	1.17 To access the instrument	28
1.9.1 Acquisition modes.	6	1.18 Modular architecture	28
1.9.2 Signal ranges	7	1.19 Precautions on installation	29
1.9.3 Number and type of cells accepted	7	1.20 Warranty	29
1.9.4 Mechanical dimensions (mm (<i>in</i>))	7	1.21 CE declaration of conformity	29
1.9.5 Gross weight, net and tare	7	2. Output and control modules	30
1.10 Included functions.	8	2.1 Module R1	30
1.11 'Tare' functions included	8	2.2 Module T1	30
1.12 Configuration	9	2.3 Module SSR	31
1.12.1 How to operate the menus	9	2.4 Module AO	31
1.12.2 Initial set-up	10	2.5 Module RTU	32
1.12.3 Initial setup menu	11	2.6 Module S4	32
1.12.4 Function 'auto-tare'	12	2.7 Module S2	33
1.12.5 Scale factor	12	2.8 Modules R2, R4, R6	33
1.12.6 Function 'stock'.	12	3. Other options	34
1.12.7 Advanced configuration menu	13	3.1 Option NBT	34
1.12.8 Alarms.	14	3.2 Option G	34
1.12.9 Alarm configuration	15	4. Accessories	35
1.12.10 Display filters	16	4.1 THM benchtop housing.	35
1.12.11 Rear controls	17	4.2 Adapter DRA-M	35
1.12.12 Front key 'LE' (◀).	17	4.3 Adapter KA96	35
1.12.13 Fast access.	18	4.4 WME wall housing	35
1.12.14 'On power up' function.	18	4.5 Protector KIP	35
1.12.15 'Fast access' configuration menu	19		

1.3 How to order

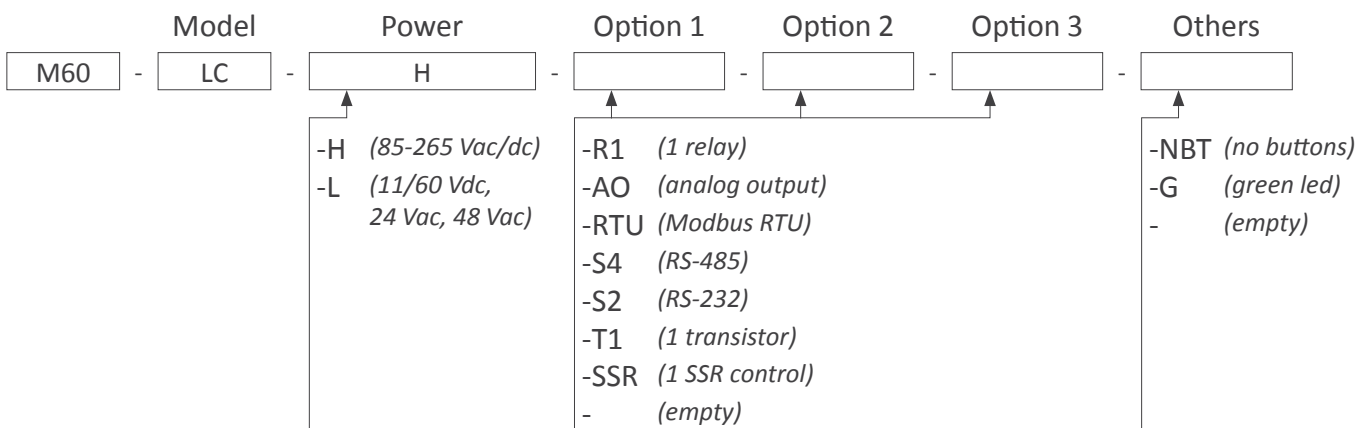

1.4 Material included

The shipment includes :

- 1 instrument M60-LC
- 1 pack of orange power terminals
- 1 pack of green signal terminals
- 1 user's manual
- 1 set of units label (see Figure 1)

If the instrument mounts output and control options (see section 2), the shipment also includes:

- 1 pack of green signal terminals for each output and control option installed

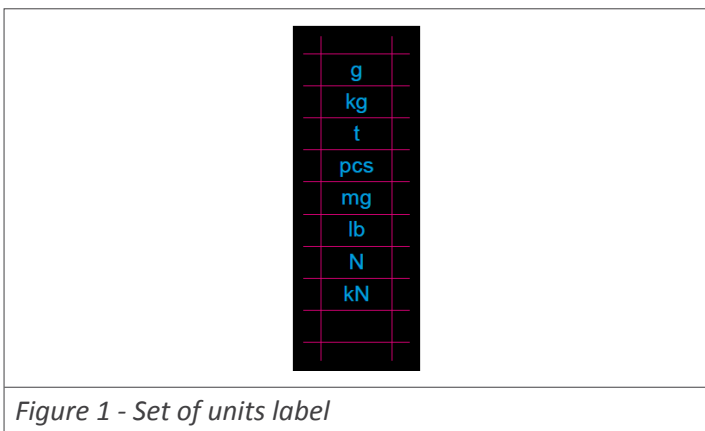
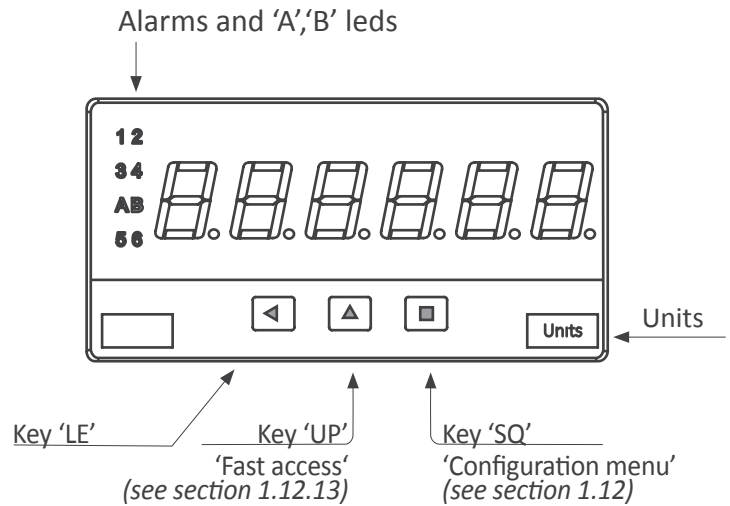

Figure 1 - Set of units label

1.5 Additional information

User's manual	<ul style="list-style-type: none"> • www.fema.es/docs/4507_M60-LC_manual_en.pdf
Datasheet	<ul style="list-style-type: none"> • www.fema.es/docs/4509_M60-LC_datasheet_en.pdf
Declaration CE	<ul style="list-style-type: none"> • see section 1.21
Warranty	<ul style="list-style-type: none"> • www.fema.es/docs/4153_Warranty1_en.pdf
Web	<ul style="list-style-type: none"> • www.fema.es/Series_M

1.6 Front view



Front leds 'A' and 'B' show the active function (see Table 1). See section 1.9.5 for a definition on gross weight, net weight and tare. The manual activation of the 'tare' activates a fast flash on led 'B'.

Reading	A	B
Gross weight	on	off
Actual tare value	off	on
'tare' function activated	off	fast flash
Net weight	off	off
Units ('stock units')	on	on

Table 1 - Meaning for the front leds 'A' and 'B'

1.7 Rear view

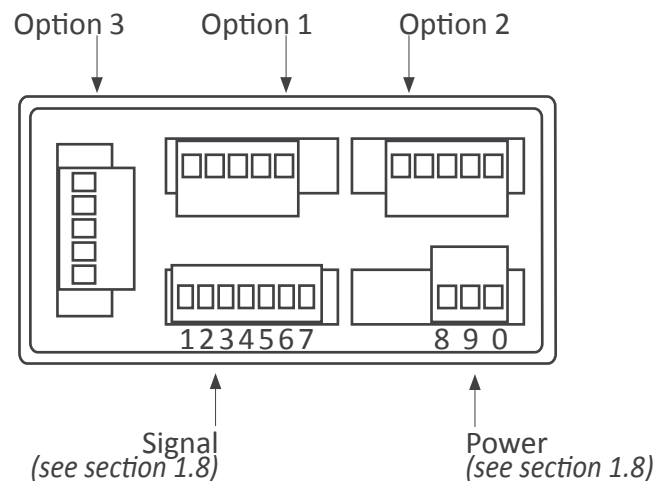

1.8 Signal and power connections

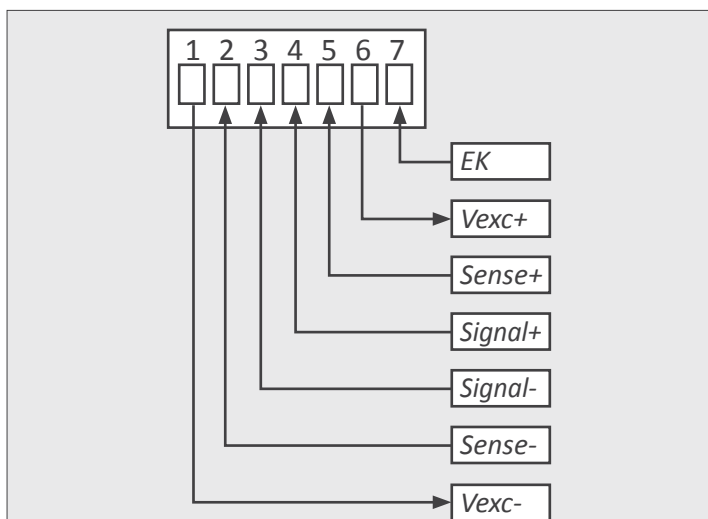

7	EK	'on/off' rear control (short circuit to 'Vexc-')
6	Vexc+	Excitation voltage +
5	Sense+	Excitation voltage sense +
4	Signal+	Signal +
3	Signal-	Signal -
2	Sense-	Excitation voltage sense -
1	Vexc-	Excitation voltage -

Figure 2 - Signal connections

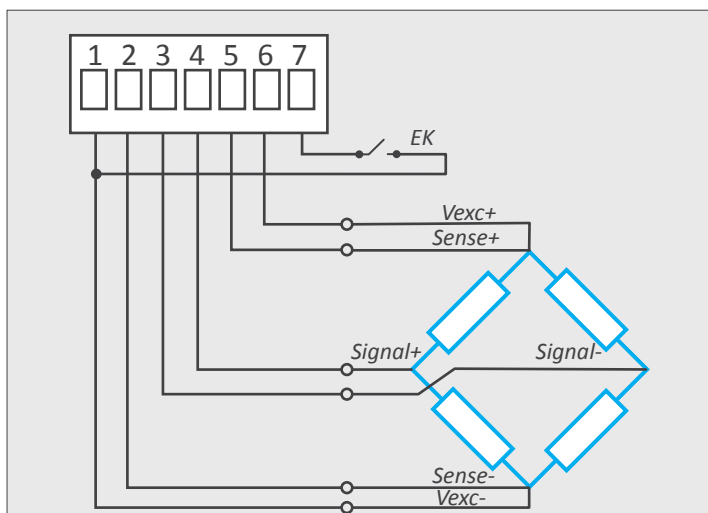
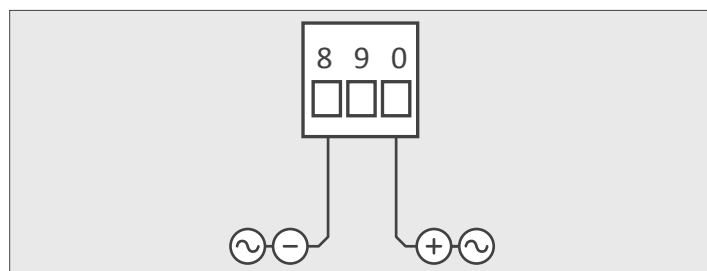

Figure 4 - Example for connections with 1 load cell.



The 'sense' terminals must be always connected. If you do not use the 'sense', shortcircuit with 'Vexc' terminals (see section 1.8.1).



8	Neutral AC / Negative DC
9	Not connected
0	Phase AC / Positive DC

Figure 3 - Power connections



Fuse : to comply with the security regulation 61010-1, add to the power line a protection fuse acting as a disconnection element, easily accessible to the operator and identified as a protection device.

- Power 'H' 250 mA time-lag fuse
- Power 'L' 400 mA time-lag fuse

1.8.1 Connecting the 'sense'

Measuring with load cells requires a stable and accurate excitation voltage. Connecting the 'sense+' and 'sense-' terminals to the load cell, provides the instrument with an accurate value of the excitation voltage received by the cell. Deviations and errors from the standard excitation value are automatically compensated by the instrument, increasing the accuracy and reliability of the measure.

If you do not wish to use the 'sense', place a shortcircuit between terminals 'sense+' and 'Vexc+', and between terminals 'sense-' and 'Vexc-'.

For applications with multiple cells (2, 3, 4 cells or more) connect the 'sense' wires to the 'electrical middle point' of the power wires of all the cells (see section 1.16.4).

1.8.2 Connecting the cell to the ground

Measuring with load cells requires an electrically clean installation. When connecting the ground to the cell system, assure that :

- the cell connection to ground is performed in such a way that the current to ground DOES NOT flow through the cell.

1.8.3 Real cases

See section 1.16 for different examples on how to connect the load cell and configure the instrument.

1.9 Technical specifications

Digits

number of digits	6
led	7 segments
color	red or green
digit height	14 mm

Reading

max. reading	999999
min. reading	-199999
decimal point	configurable X.X.X.X.X.X
overrange	flash reading
underrange	flash reading

Load cells

type of cells	1 mV/V, 2 mV/V, 3 mV/V and others
excitation voltage	configurable 5 Vdc or 10 Vdc
max. excitation current	140 mA
Vexc. protection	against shortcircuit (see error at section 1.15)
max. terminals voltage	30 Vdc
number of cells*	1 to 8 load cells (power 5 Vdc) 1 to 4 load cells (power 10 Vdc)

*(values calculated for standard 350 Ohms load cells. For cells with different impedance, the number is limited by the 140 mA available current)

Measure

signal ranges	(see section 1.9.2)
accuracy at 25 °C	(see section 1.9.2)
thermal stability	50 ppm/°
input impedance	20 MOhm
acquisitions/second	see Table 2
(and refresh for alarms, analog outputs and bus)	
display refresh	see Table 2

step response	see Table 2 0% to 99% signal
signal terminals	plug-in screw terminals (pitch 3.81 mm)

Power

power 'H'	85 to 265 Vac/dc
power 'L'	11 to 60 Vdc and 24/48 Vac
isolation*	2500 Veff with power 'H'
*(60 seconds)	1500 Veff with power 'L'
consumption	<1.5 W only meter <4.0 W meter with options
power terminals	plug-in screw terminals (pitch 5.08 mm)
wire section	1 to 2.5 mm ² (AWG17 to AWG14)

Configuration

front keypad with 3 keys

Front protection

IP65

Output and control options

relay, analog, communications, ...
(see section 2)

Mechanical

mounting	panel
connections	plug-in screw terminal
housing	ABS, polycarbonate (V0)
weight	<150 gr.
front size	96 x 48 mm (1/8 DIN)
panel cut-out	92 x 44 mm
depth	91 mm (including terminals)

Temperature

operation	0 to +50 °C
storage	20 to +70 °C
warm-up time	15 minutes

1.9.1 Acquisition modes

The instrument works by default with a fast acquisition mode of 16 acquisitions per second, with a noise rejection optimized for 50 and 60 Hz frequencies. Two additional faster acquisition modes are available, optimized for noise rejection to a single specific frequency of 50 Hz or 60 Hz.

To optimize the noise rejection only to 50 Hz and/or increase the acquisition speed to 50 acquisitions per second, configure

the 'Mode' ('ModE') parameter to '50.hZ' value. This selection increases the speed to 50 acquisitions per second and increases the noise rejection to 50 Hz, although it reduces the noise rejection to 60 Hz. Configure the parameter value to '60.hZ' to increase to 60 acquisitions per second and maximum rejection to 60 Hz noise, reducing the noise rejection for 50 Hz.

To configure the mode see section 1.12.7.

	Acquisitions/sec.	Display refresh	Step response
Mode standard	16 acq./sec.	16 refresh/sec.	63 mSec.
Mode 50 Hz	50 acq./sec.	16 refresh/sec.	20 mSec.
Mode 60 Hz	60 acq./sec.	16 refresh/sec.	17 mSec.

Table 2 - Technical data for the configured acquisition mode

1.9 Technical data (cont.)

1.9.2 Signal ranges

The instrument works with 6 internal signal ranges and the active range is automatically selected when the instrument is started. The selection depends on the value of the two parameters : 'Sensitivity' ('MV.V') and 'Excitation voltage' ('V.EXC') (see section 1.12.2)

Example : with a sensitivity configuration of 2.0000 mV/V and a configured excitation voltage of 10 Vdc, the instrument selects the 20 mV input signal range, by calculating $2\text{ mV/V} \times 10\text{ Vdc} = 20\text{ mV}$.

The internal signal ranges available are shown below at Table 3.

Signal ranges	Accuracy	Max. input signal
0/100 mVdc	0.05% FS	30 V
0/30 mVdc	0.05% FS	
0/20 mVdc	0.05% FS	
0/15 mVdc	0.05% FS	
0/10 mVdc	0.05% FS	
0/5 mVdc	0.05% FS	

Table 3 - Input signal ranges

1.9.3 Number and type of cells accepted

The instrument accepts connection for up to 8 standard 350 Ohms load cells. With a configured excitation voltage of 10Vdc connect from 1 to 4 load cells. With a configured excitation voltage of 5Vdc connect from 1 to 8 load cells. For load cells with different impedance, calculate the current consumption for each cell, and the total must not exceed the maximum current the instrument can provide.

In case of problems with the power or the signal provided by the load cells, the instrument provides three functions for troubleshooting purposes. These functions allow to access the signal input value (in mV), the excitation voltage value at the 'sense' terminals (in Vdc) and the current provided to the cells (in mA). The operator can use this values to identify the cause of the problem. See section 1.12.13 for more information on how to access this values in real time.

1.9.4 Mechanical dimensions (mm (in))

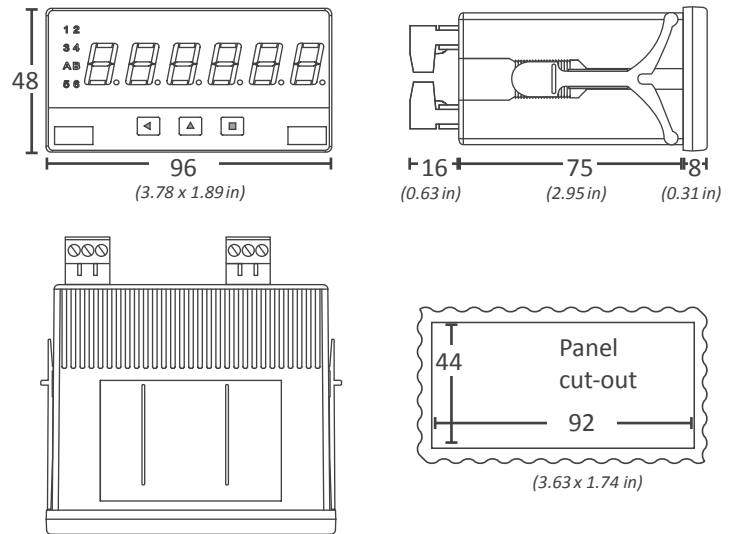

1.9.5 Gross weight, net and tare

The instrument shows the value for the net weight, and can be configured to switch reading to gross weight and the actual value of the tare. The relation between them is :

- Net weight = gross weight - tare

Operator can access these values by configuring the fast access menu (key 'UP (▲)') (see section 1.12.13).

Reading the gross weight or tare values activate the front leds 'A' and 'B' (see section 1.6).

1.10 Included functions

Included functions		Section
Function tare	yes	1.11
Auto-tare	automatic zero tare	1.12.4
Maximum tare	to prevent undesired tare activations	1.12.7
Scale factor	change the reading scale	1.12.5 1.12.7
Stock of units	counts units instead of weight	1.12.6
Modes	high rejection to 50Hz and 60Hz	1.9.1
Alarms	standard stability alarms double setpoint activation delays deactivation delays hysteresis inverted relay locked deactivation	1.12.8
Display filters	fixed digits recursive 'steps' left zeros	1.12.10
Rear controls	activate functions from rear terminal	1.12.11
Front key 'LE' (◀)	activate functions from key 'LE' (◀)	1.12.12
Fast access (key 'UP' (▲))	fast access to parameters from front key 'UP' (▲)	1.12.13
On power up	activate functions at power up	1.12.14
Memory	maximum and minimum	1.12.13
Password	blocks access to configuration menu	1.12.17
Troubleshooting functions	values for input signal, excitation voltage and excitation current	1.9.3 1.12.13
Display brightness	5 levels	1.12.17

Table 4 - Functions included

1.11 'Tare' functions included

Activate the tare function to force the instrument to take the actual signal as a '0' weight. The tare function does not modify the internal calibration of the cell, and can be activated as many times as needed. The tare function is typically used to set a '0' reading when a fixed weight has been added to the load cell.

Example : a truck enters a loading area and is placed on a weighing system. The instrument indicates that the weight of the truck is 2.500 Kg. A tare is applied to the instrument, and now the reading is 0 Kg. The truck enters the loading area and when it leaves, it is placed on the weighing system again. Now the reading is 1.550 Kg. This is the weight of the material loaded on the truck. When the truck leaves the weighing system the instrument reads -2.500 Kg. Activate a tare again to force a reading of 0 Kg or wait for a new truck.

The instrument accepts different ways to activate the tare function:

- from the rear terminal, shortcircuit the 'EK' terminal against the 'Vexc-' terminal. Previously, configure the 'EK' terminal with the tare function (see section 1.12.11).
- from the front keypad, press the front key 'LE' (◀). Previously, configure the 'LE' (◀) key with the tare function (see section 1.12.12).
- automatically when the instrument starts. Previously, configure the 'on power up' function with the tare function (see section 1.12.14).
- automatically with the 'auto-tare' function. The inherent mechanical characteristics of a load cell makes the 'zero weight' signal a non constant value. This can be detected by placing and removing the same weight from a load cell, several times. When the weight is removed, the reading is not always '0', but a random value close and around '0'. The 'auto-tare' function automates the activation of the 'tare' when the reading of the instrument is stable and close to '0' (see section 1.12.14).

To avoid accidental tares, the instrument provides the '**Max. Tare**' ('MAX.t') parameter. The activation of the 'tare' function, either manual or automatic, is not applied if the reading is higher than the value defined in this parameter (see section 1.12.7).

The actual tare value can be accessed from the front key 'UP' (▲) activating the 'Tare' function at the 'Key UP' menu (see section 1.12.15). A reset to the tare value can be applied also from this same menu.

1.12 Configuration

1.12.1 How to operate the menus

The instrument has two menus accessible to the user :

'Configuration menu' (key 'SQ') (■)

'Fast access' menu (key 'UP') (▲)

Configuration menu

The 'configuration menu' modifies the configuration parameters to adapt the instrument to the application needs. To access the 'configuration menu' press for 1 second the 'SQ' (■) key. This access can be blocked by activating the 'Password' ('PASS') function. While operating the 'configuration menu', the alarm status is 'hold' to the status it had before accessing the menu, and the output and control modules remain in 'error' state. When leaving the 'configuration menu', the instrument applies a system reset, followed by a brief disconnection of the alarms and the output and control modules. Functionality is then recovered.

For a detailed explanation on the 'configuration menu' see the following sections, and for a full view of the 'configuration menu' see section 1.13.

'Fast access' menu'

The 'fast access' menu is an operator configurable menu, providing fast and direct access to the most usual functions of the instrument with a single key pad stroke. Press key 'UP' (▲) to access this menu.

See section 1.12.15 for a list of selectable functions for the 'fast access' menu in this instrument. The 'Password' ('PASS') function does not block access to this menu. Accessing and modifying parameters in the 'fast access' menu does not interfere with the normal functionality of the instrument, and it does not generate any system reset when validating the changes.

Operating with the front keypad inside the menus

Key 'SQ' (■) - press the 'SQ' (■) key for 1 second to access the 'configuration menu'. Inside the menu, the 'SQ' (■) key acts as an 'ENTER'. It enters into the menu option selected, and when entering a numerical value, it validates the number.

Key 'UP' (▲) - press the 'UP' (▲) key to access the 'fast access' menu. Inside the menu, the 'UP' (▲) key sequentially moves through the available parameters and menu entries. When entering a numerical value, it modifies the digit selected by increasing its value to 0, 1, 2, 3, 4, 5, 6, 7, 8, 9.

Key 'LE' (◀) - press the 'LE' (◀) key to activate the configured special functions associated to this key. Inside the menu, the 'LE' (▲) acts as an 'ESCAPE'. It leaves the selected menu level and eventually, by leaving all menu levels, it

leaves from the configuration menu. Then changes are applied and the instrument is back to normal function. When entering a numerical value, it selects the active digit, and the value is then modified by key 'UP' (▲).

'Rollback'

After 30 seconds without interaction from the operator, the instrument will rollback and leave the 'configuration menu' or the 'fast access' menu. All changes will be discarded.

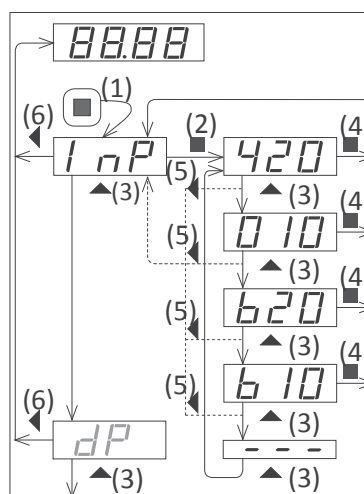

Example of operation inside the 'configuration menu'.

1. The (■) key enters into the 'configuration menu'.
2. The (■) key enters into the 'InP' menu.
3. The (▲) key moves through the menu options.
4. The (■) key selects the desired range and returns to the 'InP' menu.
5. The (◀) key leaves the actual level and moves to the previous menu level.
6. The (◀) key leaves the 'configuration menu'. Changes are applied and saved at this moment.

Figure 5 - Example of operation inside the 'configuration menu' (menu entries are given as example, and may not be the exactly the same as the instrument menu entries).

1.12.2 Initial set-up

Before starting to configure the instrument, identify the parameters of the load cell, at the manufacturers datasheet (see Table 5). If the parameters are not know, leave the instrument with the default values.

Load cell parameters	Default values
Sensitivity	2 mV/V
Nominal weight	1000 Kilos
Excitation voltage	10 Vdc

Table 5 - Parameters of the load cell

For an accurate measure, the instrument needs to correctly configure its parameters for the particular load cell connected. The configuration procedure has a first theoretical step and a second empirical step. The third and final step will set the 'system zero' of the instrument.

Theoretical configuration of the load cell

The theoretical parameters are configured at the 'Parameters of the cell' ('cELL') menu.

- at the 'Decimal point' ('dP') parameter, place the decimal point according to the resolution you want to see.
- at the 'Nominal weight' ('LoAd') parameter introduce the nominal weight of the load cell. The value is entered with the resolution configured in the parameter above.
- at the 'Sensitivity' ('MV.V') parameter, introduce the value of the cell sensitivity.
- at the 'Excitation voltage' ('V.EXc') parameter, select 5 or 10Vdc. (The 'LAB' value enables the laboratory mode, for direct measure from a millivolt generator instead of a load cell (see section 1.16.5)).

Example : load cell with 1.95 mV/V sensitivity and a nominal value of 5 Kg and power 5 Vdc. To read in grams with a decimal point, configure the theoretical parameters as indicated below :

Decimal point : XXXXX.X
 Sensitivity : 1.95 mV/V
 Nominal weight : 5000.0
 Excitation voltage : 5 Vdc

When the theoretical values are configured, leave the configuration menu. Apply a 'system zero'. Force a tare, and place different weights to check if the reading is correct. If it is not correct, apply the empirical configuration and again the 'system zero'.

Empirical configuration of the load cell

The second part of the load cell configuration is an empirical process of field correction. The instrument will detect and

correct the individual deviations of this particular load cell.

For the empirical configuration you will need access to two weights : a low weight, as small as possible (it can be the cell without weight) and a high weight as close as possible to the nominal weight of the cell.

In each case the meter will be informed of the real weight applied to the cell in order to correct and compensate for the measured deviations at the signal. Both corrections are need (high and low) for a correct configuration of the load cell.

- low weight correction : place the load cell without weight or with the smallest weight possible, and access the 'Low weight correction' ('F.Lo') menu. Press key SQ ('■'), introduce the value of the weight and press again SQ ('■'). The instrument will flash shortly and return to the menu entry 'Low weight correction' ('F.Lo').
- high weight correction : place the load cell with a weight closest to nominal and access the 'High weight correction' ('F.hI') menu. Press key SQ ('■'), introduce the value of the weight and press again SQ ('■'). The instrument will flash shortly and return to the menu entry 'High weight correction' ('F.hI').

Once both corrections are applied, leave the configuration menu. Force a tare, and place different weights to check that the reading is correct. As a last step, assign the 'system zero' if you want to access gross weight and net values.

Assign the 'system zero'

This is a necessary and important step for a correct measurement with a load cell.

- assign the 'system zero' : place the load cell without weight or with the weight that will be considered as 'zero' and access the 'System zero' ('S.ZEr') parameter. Press key SQ ('■'). The instrument will flash shortly and return to the menu entry 'System zero' ('S.ZEr').



The empirical configuration of the load cell recalculates and updates the theoretical sensitivity value ('Sensitivity mV/V' ('MV.V') parameter). Manual modifications of this parameter will modify the configuration of the cell. To prevent accidental modification consider the activation of the 'password' function (see section 1.12.17).



Once the load cell has been correctly configured, and the reading of the instrument is correct, it is not necessary to access again this part of the configuration menu. If you need to scale the reading to different units, use the 'Scale factor' ('ScL.F') parameters at the 'Advanced configuration' menu (see section 1.12.7).

1.12.3 Initial setup menu

Press 'SQ' (■) for 1 second to access the 'configuration menu'. For a description on how to operate inside the menus see section 1.12.1. For a full vision of the 'configuration menu' structure see section 1.13.

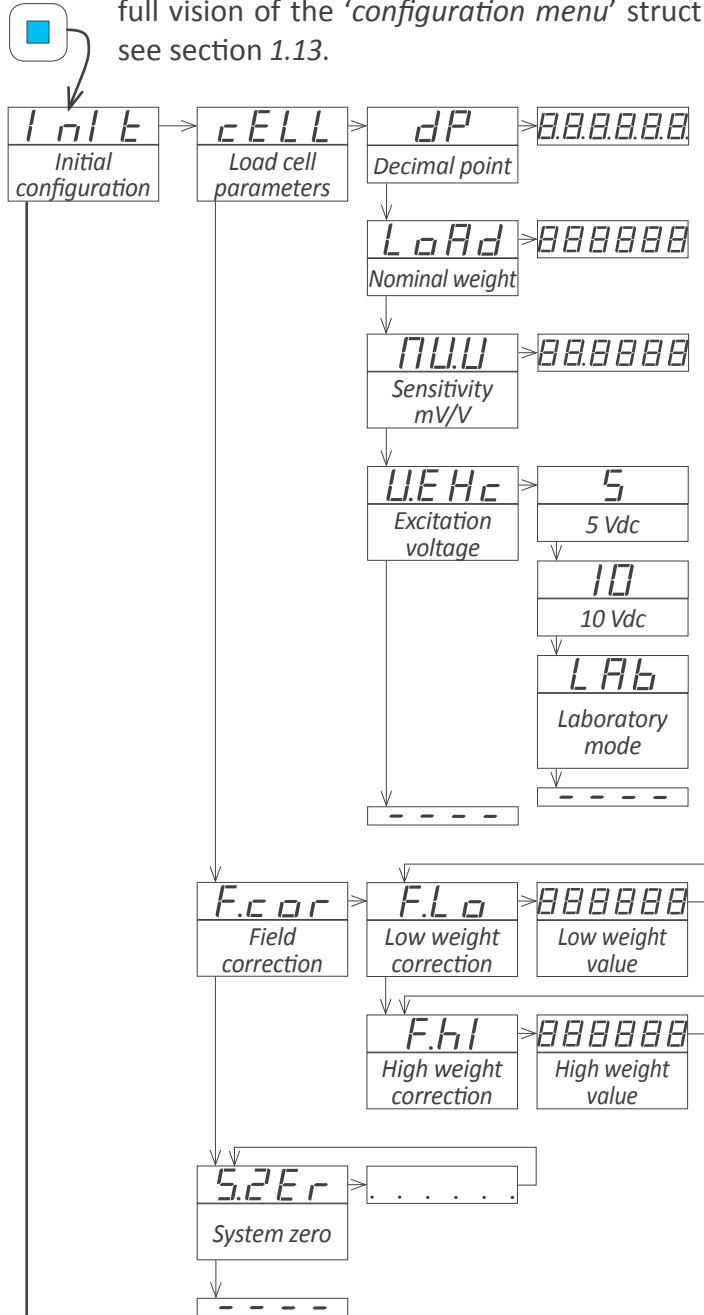

At the initial set up of the instrument, first configure the theoretical part of the load cell at the 'Load cell parameters' ('cELL') menu and later configure the empirical part of the load cell at the 'Field correction' ('F.cor') menu. See section 1.12.2 for additional information.

- at the 'Decimal point' ('dP') parameter, select the decimal point position. Move the decimal point with key 'LE' (◀). The position defined will be used for all reading parameters.

Example : to read in 'Kg' with tenths of kilograms, place the decimal point at 'XXXXX.X' and the reading will be always be shown with 1 decimal.

Changing the position of the decimal point will only light a different decimal point led, but will not modify or re-scale the measure of the instrument.

- at the 'Sensitivity mV/V' ('S.V') parameter, configure the value for the load cell sensitivity. Accepts any value between 0.0001 and 99.9999 mV/V. Default value is 2.0000 mV/V.
- at the 'Nominal weight' ('LoAd') parameter, configure the nominal weight of the load cell. accepts any value between 0 and 999999. The decimal point will be shown in the position configured at the 'Decimal point' ('dP') parameter. Default value is 1000.

Example : for a 5 Kg cell, configure a value of 5000 to read in grams.

- at the 'Excitation voltage' ('V.Exc') parameter, configure the voltage to power the load cell. Select '5 Vdc' or '10 Vdc'. Default value is 10 Vdc. Select 'LAB' for a millivolt meter mode in laboratory (see section 1.16.5).

The 'Field correction' ('F.cor') menu includes the functions for the empirical configuration of the load cell. See section 1.12.2 for additional information on each function.

- at the 'Low weight correction' ('F.Lo') parameter, introduce the real value of the actual weight at the cell. Use the lowest weight possible, close to 0. Press key SQ (■) to start the correction process.
- at the 'High weight correction' ('F.hI') introduce the real value of the actual weight at the cell. Use the lowest weight possible, close to nominal weight of the cell. Press key SQ (■) to start the correction process.

The 'System zero' ('S.ZEr') entry assigns the actual weight to the 'system zero' of the instrument. See section 1.12.2 for additional information.

1.12.4 Function 'auto-tare'

The 'auto-tare' function automatically activates the 'tare' when the weight is removed from the load cell. The 'auto-tare' configuration has three parameters :

- Activation value : the 'auto-tare' function activates when reading is lower than the defined value.
- Stability band: reading must be stable, and its fluctuation must be lower than the number of counts defined in this parameter.
- Stability time : reading must be within the stability band for the time defined in this parameter.

When these three parameters are met (the system is 'without weight' and the reading is 'stable') the 'auto-tare' function automatically activates the 'tare'.

Example : weighing system with reading from 0.0 to 2500.0 Kg. When weight is removed from the system, there is always a variable remnant value : 2.2 Kg, 3.1 Kg, -0,7 Kg, ... This remnant value is associated to the specific imperfections of each load cell. Also this remnant value takes some time to stabilize, approximately 1 second. A manual tare can be applied each time the load cell is unloaded in order to correct this error. The 'auto-tare' function will correct it automatically without operator intervention, configuring the following parameters.

- activation value = 5.0
- stability = 1.0
- stability time = 2 seconds

When reading is lower than '5.0', the 'auto-tare' system activates, and it will analyze the stability of the signal. When reading does not change more than ± 1.0 counts for a time of 2 seconds, the tare will automatically activate.

The 'auto-tare' function is affected by the '**Maximum tare**' ('MAX.t') parameter. The instrument will not accept the activation of the tare when reading is higher than the '**Maximum tare**' ('MAX.t') value.

1.12.5 Scale factor

The '**Scale factor**' ('SCL.F') configures a fixed multiplier to apply to the reading.

Example: a weighing system is configured to read in Kg, but the system is going to be shipped to an area where measure must be in pounds. The relation between kilograms and pounds is: 1 Kg=2,20462 pounds. Within the scale factor, configure the multiplier to 220462 and the divider to 100000. The instrument is now configured to read in 'pounds'.

1.12.6 Function 'stock'

The '**Stock units**' ('Stck') function is provided to count large quantities of small units, in situations such as stock inventory, reception of goods, etc. The operator must configure the number of 'units' assigned to a weight. The instrument will measure the weight but will show the number of 'units'.

To configure the '**Stock units**' function, weight a known number of units. Then introduce the number of units, either from the configuration menu ('Advanced configuration' \ 'Stock units') or from the fast access menu (key 'UP' (▲)).

Example from the configuration menu : place 50 units on the load cell, and check that the instrument is weighing correctly. Enter the configuration menu, and at the 'Stock units' ('Stck') parameter, within the 'Advanced configuration', introduce '50' as the number of units. Save the value (key 'SQ' (■)) and leave the configuration menu (key 'LE' (◀) two times). The instrument restart and reads 50 units. Add more units and observe that the reading increases proportionally to the number of units.

Example from the front key 'UP' (▲) : configure the function 'Stock units' to be accessible from the front key 'UP' (▲) (fast access menu) (see section 1.12.13) and leave the configuration menu. Place 50 units on the load cell, and check that the instrument is weighing correctly. Access the parameter 'Stock units' through the front key 'UP' (▲), and configure the number of units actually on the load cell (50 units). Save the value (key 'SQ' (■)) and leave the fast access menu (key 'LE' (◀)). The instrument reads 50 units. Add more units and observe that the reading increases proportionally to the number of units

In both cases, setting a value to the '**Stock units**' ('Stck') parameter assigns the value to the actual weight. The actual value of units ('**Stock units**' ('Stck') parameter) can be assigned to the actual weight by pressing front key 'LE' (◀) (see section 1.12.12) and/or activating the rear terminal 'EK' (see section 1.12.11).

Assign the value '0' to the '**Stock units**' ('Stck') parameter to disable this function and return to normal reading of weight.

1.12.7 Advanced configuration menu

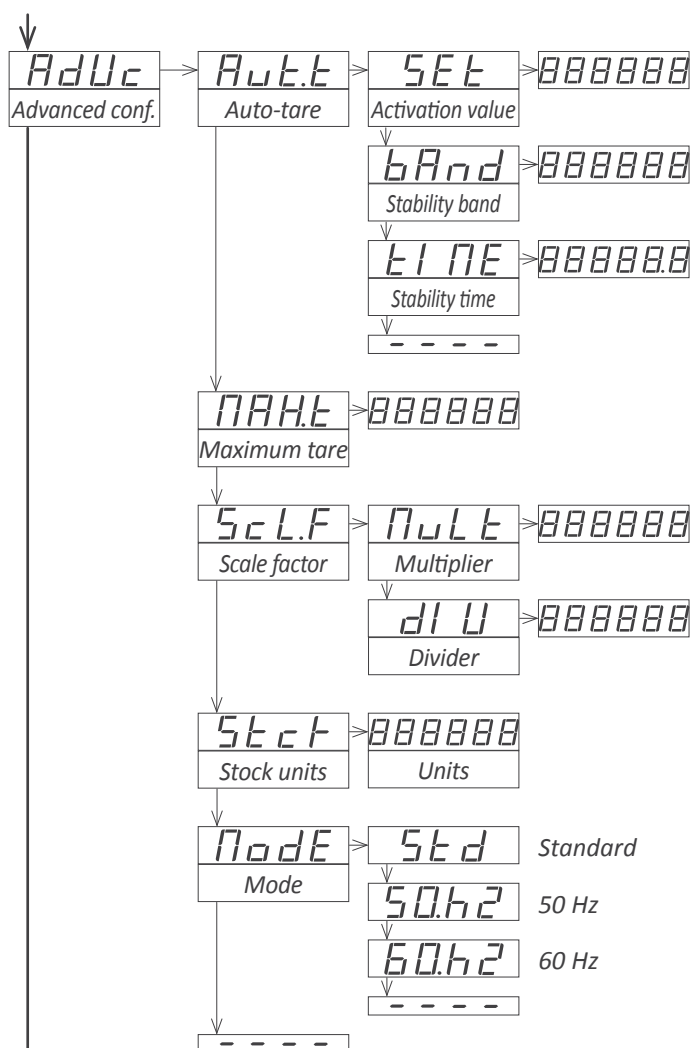

At the **'Auto-tare'** (**'Aut.t'**) menu configure the activation value and stability values to control the automatic activation of the tare, when weight is removed from the cell. See section 1.12.4 for additional information.

- at the **'Activation value'** (**'SET'**) parameter, configure the working limits for the 'auto-tare'. The 'auto-tare' only activates for lower values of reading. Accepts any value between 0 and 999999. Default value is 1000.
- at the **'Stability band'** (**'bAnd'**) parameter, configure the number of counts allowed to consider a signal 'stable'. The 'auto-tare' only activates if the reading fluctuates within this band of counts. Accepts any value between 0 and 999999. Default value is 10.
- at the **'Stability time'** (**'tIME'**) parameter, configure the minimum time, in tenths of second, for the signal to be within the stability band to consider it 'stable'. Accepts any value between '0.0' and '99999.9'. Default value is '0.0'.

Value 0 at the stability band and/or 0.0 at the stability time, disable the 'auto-tare' function.

The tare is automatically activated when reading is lower than the activation value, and the fluctuation of the reading is lower than the counts defined at the 'stability band' for the time defined at the 'stability time'.

At the **'Maximum tare'** (**'MAX.t'**) parameter, configure the maximum value of reading to allow for a tare to be applied. See section 1.12.4 for additional information. Accepts any value between 0 and 999999. Default value is 999999.

At the **'Scale factor'** (**'SCL.F'**) parameter, configure the value for the multiplier and the divider. See section 1.12.5 for additional information. Accepts any value between 0 and 999999. Default value is 1.

At the **'Stock units'** (**'Stck'**) parameter, configure the number of units for the actual weight. See section 1.12.6 for additional information. Accepts any value between 0 and 999999. Default value is 0 (function disabled).

At the **'Mode'** (**'ModE'**) parameter, configure the acquisition mode. See section 1.9.1 for additional information. Default value is **'Standard'** (**'Std'**).

1.12.8 Alarms

The instrument manages 3 independent internal alarms, each one controlling the activation of an optional relay, transistor or SSR control output. These outputs are optional (see section 2) and are installed at the free slots of the instrument (see section 1.18).

The instrument has three front leds that reflect the state of the three internal alarms, identified as '1', '2' and '3'. For options with 4 and 6 relay outputs, see special modules R2, R4 and R6 at section 2.8.

• **Configurable parameters**

Each alarm has several configuration parameters, starting with the usual setpoint, hysteresis and maximum (alarm active when reading is higher than setpoint) or minimum (alarm active when reading is lower than minimum) alarm types (see Figure 6).

• **Activation and deactivation delays**

Each alarm can configure independent activation and deactivation delays. These delays affect the alarm as a whole, and the delay will affect the front led and the associated relay.

• **Stability activation**

The stability activation delays the alarm activation until the reading is stable (see Figure 7).

Application : the filling of a tank with liquid is controlled with a load cell. Upon reaching 5000 liters, the alarm 1 activates to stop the filling pump. After the pump has stopped, the liquid is still moving inside the tank, and this movement is reflected in weight and reading oscillations. Alarm 2 is configured as 'stability alarm' and activates when the liquid inside the tank is at rest. At this moment, the tank can be removed safely.

• **Second setpoint**

Configuring a second setpoint creates 'windowed alarms'. The windowed alarm controls with a single relay output if the reading is inside or outside the values defined (see Figure 8).

• **Inverted relay**

Activate the 'inverted relay' function to invert the activation logic of the associated relay.

• **'Locked alarms'**

Activate the 'locked alarms' function to force the operator to interact with the instrument when an alarm has activated. Once activated, the alarm will remain locked at active state, even if the reading returns to a value below setpoint, until the operator manually unlocks the alarms by pressing the front key 'LE' (◀).

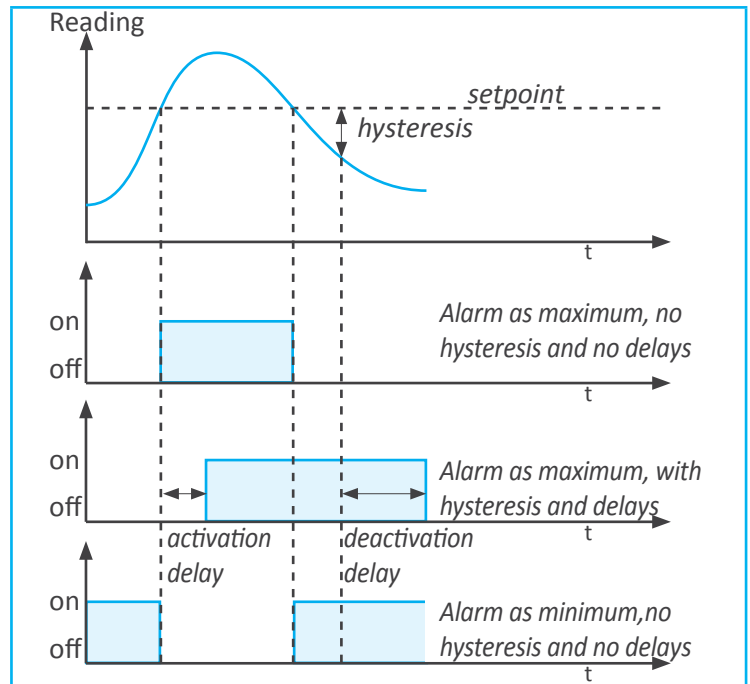

Figure 6 - Examples of alarms with 1 setpoint

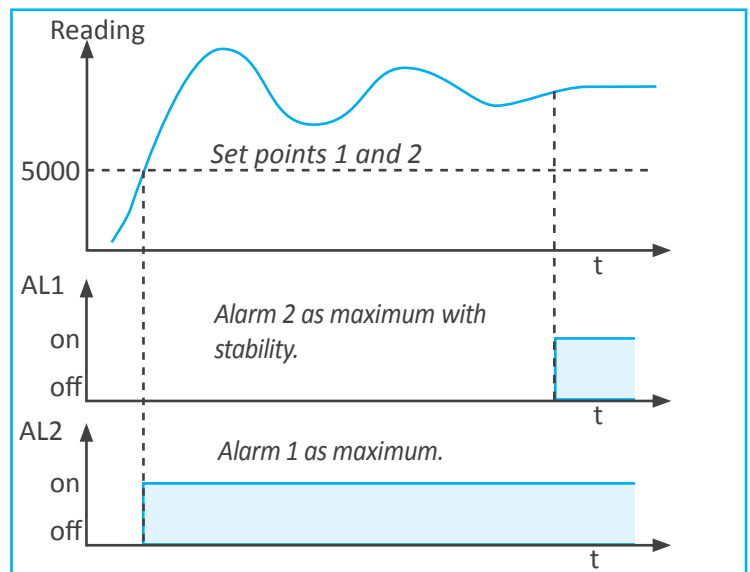

Figure 7 - Example of alarm with stability

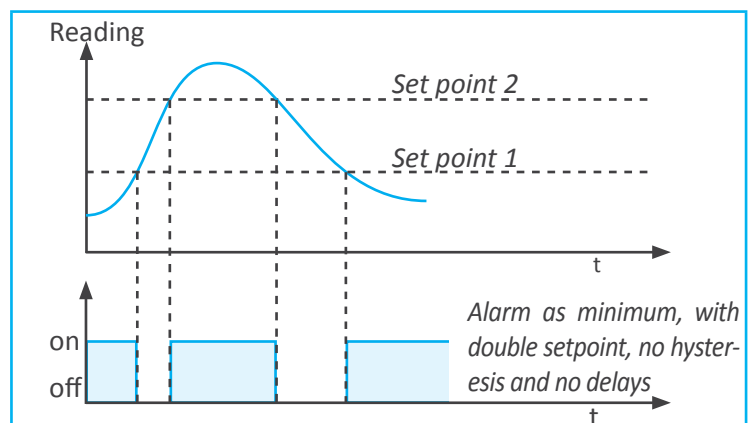
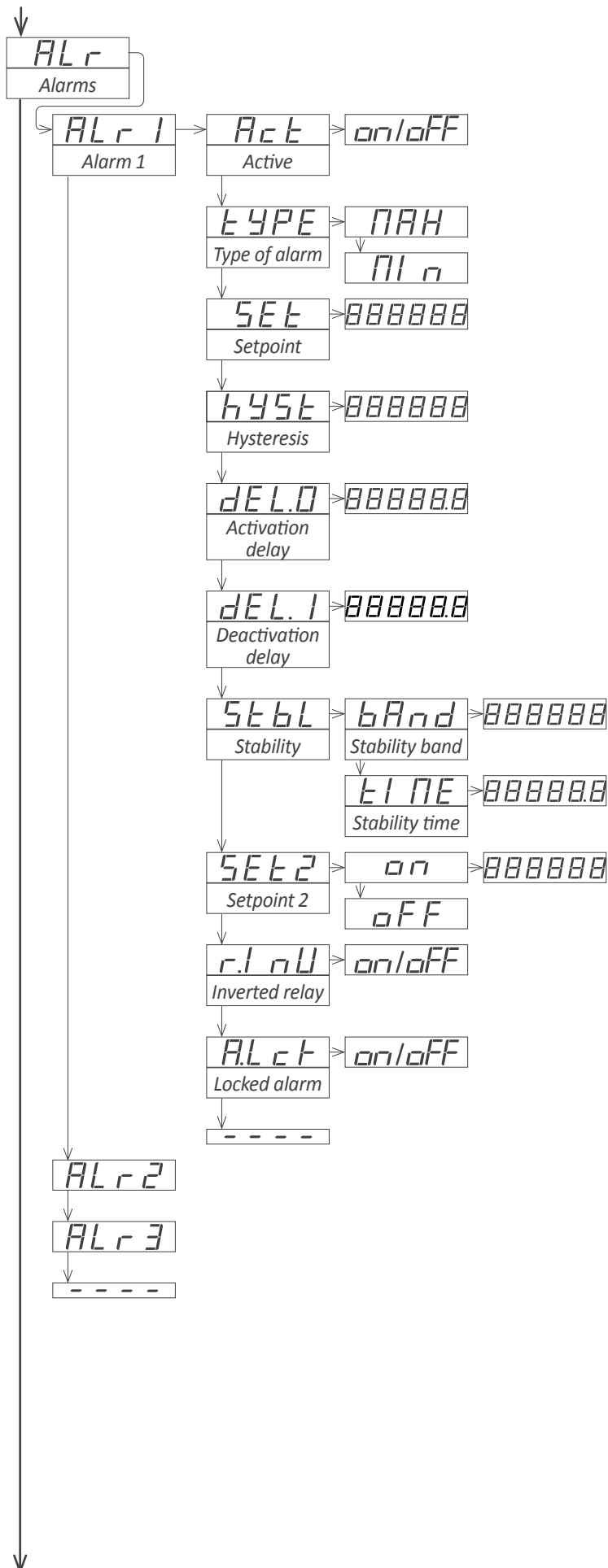

Figure 8 - Example of alarm with double setpoint

1.12.9 Alarm configuration



Alarms 1, 2 and 3 are configured from menu 'ALr1', 'ALr2' or 'ALr3'. See section 1.12.8 for additional information.

- at the 'Active' ('Act') parameter select 'on'
- at the 'Type of alarm' ('Type') parameter, select 'MAX' for maximum alarm (activates when reading is higher than setpoint), or 'Min' for minimum alarm (activates when reading is lower than setpoint).
- at the 'Setpoint' ('SEt') parameter, configure the alarm activation point. Value accessible through the 'fast access' menu (see section 1.12.13).
- at the 'Hysteresis' ('hySt') parameter, select the hysteresis value. Hysteresis applies to the alarm deactivation. Alarm deactivates once the reading is beyond the setpoint plus the hysteresis value. Hysteresis prevents relay switching in case of signal fluctuations close to the setpoint value.
- at the 'Activation delay' ('dEL.0') parameter, configure the delay to apply before the alarm is activated. Delay starts to count once the setpoint is reached. Value from 0.0 to 99.9 seconds.
- at the 'Deactivation delay' ('dEL.1') parameter, configure the delay to apply before the alarm is deactivated. Delay starts to count once the setpoint is reached plus the hysteresis value. Value from 0.0 to 99.9 seconds.
- at the 'Stability' ('StbL') parameter, configure the conditions to detect stability at the signal and activate the alarm. Value '0' at 'stability band' or at 'stability time' deactivate the stability control of the alarm.
 - at the 'Stability band' ('bAnd') parameter, configure the number of counts that the reading can change and still be considered stable. Values from 0 to 999999. Default is 10.
 - at the 'Stability time' ('tIME') parameter, configure the time, in tenths of second, that the reading must be within the 'stability band' to be considered stable. Values from 0.0 to 99999.9. Default is 0.0.
- to work with 'windowed alarms' configure 'Setpoint 2' ('SEt2') to 'on' and configure the value for the second setpoint. The second setpoint must always be higher than the first setpoint.
- at the 'Inverted relay' ('r.Inv') parameter, configure 'on' to invert the activation of the relay. Relay is inactive when alarm is active, and relay is active when alarm is inactive.
- at the 'Locked alarm' ('A.Lck') parameter, configure 'on' to block the automatic alarm deactivation. Alarm deactivation must be performed manually, by pressing the front key 'LE' (◀) (see section 1.12.12) or rear control (see section 1.12.11).

1.12.10 Display filters

The instrument provides several functions to act upon the reading in order to increase stability, reduce noise and adapt to particular needs. These functions are grouped under the ‘Display’ (‘dISP’) menu and are explained below :

- the ‘Fixed digits’ (‘FIX.d’) function allows to fix each digit to a fixed value. Typically, one or more right digits are fixed to ‘0’. Fix digits starting from the right. Value ‘-’ indicates that the digit is not fixed.
- the ‘Average filter’ (‘AVr’) applies a recursive filter upon the reading values, in order to reduce oscillations due to noisy signals. Configure the filter strength between ‘0’ and ‘100’. The filter is stronger with higher values. Increasing the strength of the filter slows the reading. Value ‘0’ disables the filter.
- the ‘Steps’ (‘StEP’) function configures the reading to be done in steps of 1, 2, 5, 10, 20 or 50 counts.

Example: configure a step of 20 and the reading will change in steps of 20 counts (‘1420’, ‘1440’, ‘1460’, ...).

- the ‘Left zero’ (‘LZEr’) function lights all zeros to the left.
- the ‘Memory of maximum’ (‘MAX’) displays the maximum reading stored on memory. To reset this memory, select the ‘rSt’ input. The value can be accessed through the ‘fast access’ menu at front key ‘UP’ (▲) (see section 1.12.13).
- the ‘Memory of minimum’ (‘MIn’) displays the minimum reading stored on memory. To reset this memory, select the ‘rSt’ input. The value can be accessed through the ‘fast access’ menu at front key ‘UP’ (▲) (see section 1.12.13).

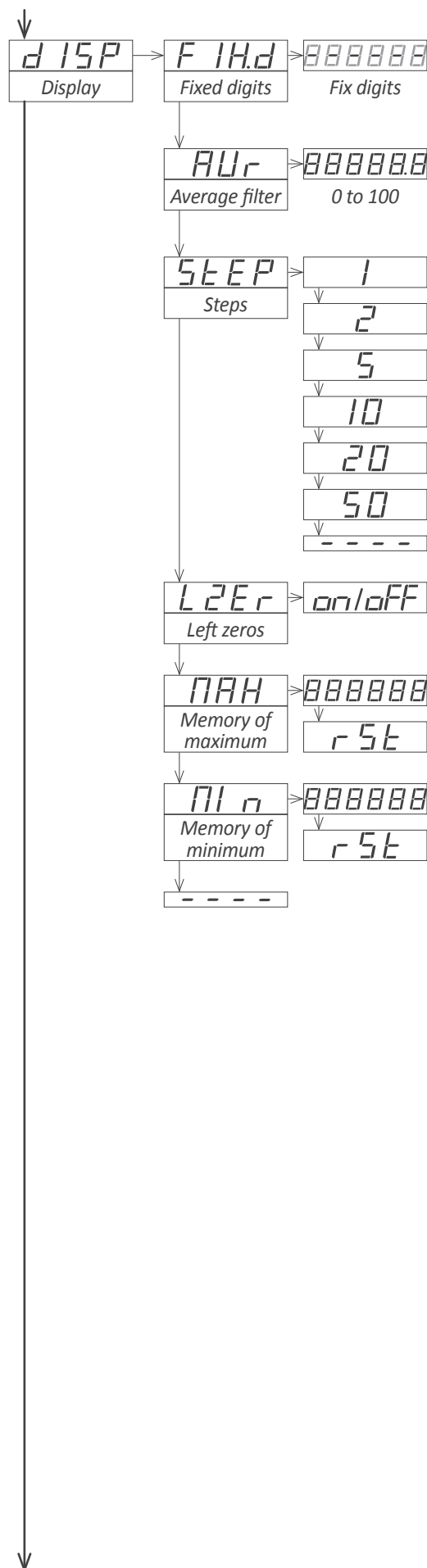

1.12.11 Rear controls

The instrument provides a digital 'on/off' input at the rear terminals, referenced as 'EK' (see section 1.8). Assign functions to this terminal and activate these functions with a short circuit between terminal 'EK' and terminal 'Vexc-'. Functions available are explained below :

- the 'Tare' ('tArE') function applies a tare.
- the 'Alarm unlock' ('A.LcK') function unlocks all alarms that are locked due to the 'Locked alarms' function (see section 1.12.8).
- the 'Stock units' ('Stck') function assigns the actual weight to the number of units defined at the 'stock units' parameter (see section 1.12.6).

In case of multiple functions enabled, the activation is performed sequentially in the same order as the configuration menu (first is the tare, then the alarm unlock, etc).

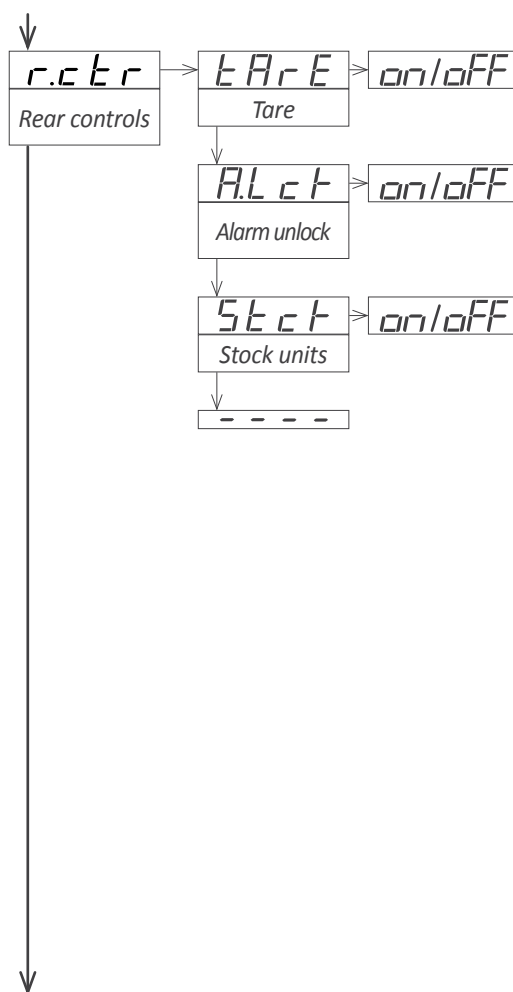

1.12.12 Front key 'LE' (◀)

The front key 'LE' (◀) can be configured to activate a set of functions. Functions available are explained below :

- the 'Tare' ('tArE') function applies a tare.
- the 'Alarm unlock' ('A.LcK') function unlocks all alarms that are locked due to the 'Locked alarms' function (see section 1.12.8).
- the 'Stock units' ('Stck') function assigns the actual weight to the number of units defined at the 'stock units' parameter (see section 1.12.6).

In case of multiple functions enabled, the activation is performed sequentially in the same order as the configuration menu (first is the tare, then the alarm unlock, etc).

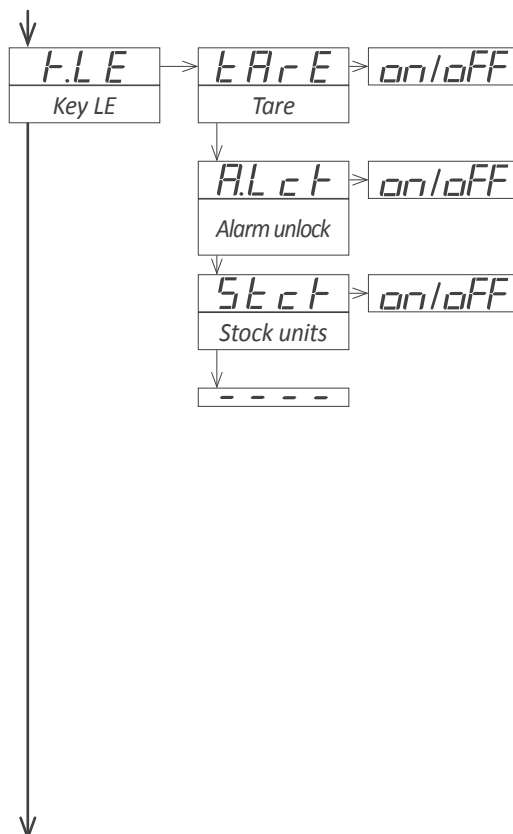

1.12.13 Fast access

The *'fast access'* is an operator configurable menu. When configured, the operator can access the most usual functions with a single press of the front key 'UP' (▲). Functions available are listed below :

- access to alarm setpoints from the front key 'UP' (▲) allows to read and modify the actual setpoint values
- access to the 'stock units' parameter from the front key 'UP' (▲) allows to read and modify the actual 'stock value' parameter. See section 1.12.6 for additional information about the 'stock units' function.
- values for 'gross weight' and 'tare' are accessible from the front key 'UP' (▲) (see section 1.9.5). To reset the tare value visualize the value and press key 'UP' (▲). When message 'rSt' appears, press key 'SQ' (■). The instrument returns to visualize the 'tare' value. Press key 'LE' (◀) to leave the menu.
- functions 'signal mV', 'exc. voltage' and 'exc. current' give access to values for the input signal measured in mV, the excitation voltage measured in Vdc between terminals 'sense+' and 'sense-', and the excitation current measured in mA provided from the instrument to the load cell

These three functions act as an integrated voltmeter and ammeter, to be used for troubleshooting purposes, as they give information on the real signals received and provided to the load cell.

- access to maximum and minimum memories from the front key 'UP' (▲) allows to visualize the values. To reset the maximum or minimum value, visualize the value, and press key 'UP' (▲). When message 'rSt' appears, press key 'SQ' (■). The instrument returns to visualize the actual memory value. Press key 'LE' (◀) to leave the menu

The *'fast access'* menu is not affected by the password function, allowing to have a locked access to the general configuration menu, while still some functions are accessible to the operator through the *'fast access'* menu.

• **Super fast access**

If only one function is configured at the *'fast access'* menu, pressing the front key 'UP' (▲) will shortly read the name of the function and then automatically show into the value.

1.12.14 'On power up' function

The **'On power up'** (**'on.Pu'**) menu allows to define a series of functions to activate when the instrument restarts after a power loss.

Functions available are a delay on the activation of measure and control functions, and a tare function.

These functions will activate only after a restart due to power-loss, they will not apply after a restart due to changes in configuration.

Delay the measure and control functions gives time to slow system elements to start completely before the instrument begins to acquire signal and control the outputs.

While on delay mode, the instrument shows all decimal points lightened and flashing, all alarms are deactivated, and there is no signal acquisition or communications control. When the delay time is over, the instrument starts its normal functioning.

1.12.15 'Fast access' configuration menu

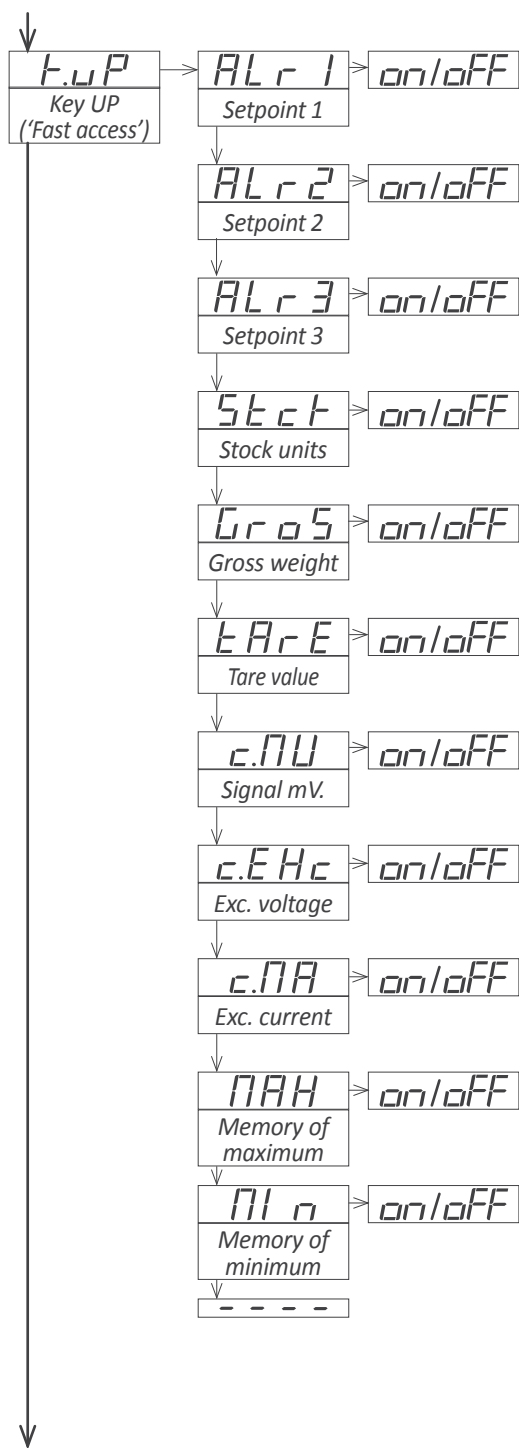

At the **'Key UP ('fast access') ('K.uP)'** menu configure which functions and parameters will be accessible through the 'fast access' menu. Select 'on' to activate each function. See section 1.12.13 for additional information.

- the **'Setpoint 1' ('ALr1)'** function allows to visualize and modify the setpoint for alarm 1.
- the **'Setpoint 2' ('ALr2)'** function allows to visualize and modify the setpoint for alarm 2.
- the **'Setpoint 3' ('ALr3)'** function allows to visualize and modify the setpoint for alarm 3.
- the **'Stock units' ('Stck)'** function allows to visualize and modify the quantity of units defined at the 'stock units' parameter (see section 1.12.6).
- the **'Gross weight' ('GroS)'** function allows to visualize the gross weight.
- the **'Tare value' ('tArE)'** function allows to visualize the actual tare value.
- the **'Signal mV' ('c.MV)'** function allows to visualize the actual value of the input signal, without scaling. Value is offered in mV.
- the **'Exc. voltage' ('c.EXc)'** function allows to visualize the actual value of the excitation voltage, measured between terminals 'sense+' and 'sense-'. Value is offered in Vdc.
- the **'Exc. current' ('c.MA)'** function allows to visualize the actual value of the current provided by the instrument to the load cell. Value is offered in mA.
- the **'Memory of maximum' ('MAX)'** or **'Memory of minimum' ('MIN)'** allows to visualize and/or reset the actual value of the maximum and minimum memory.

1.12.16 'On power up' configuration

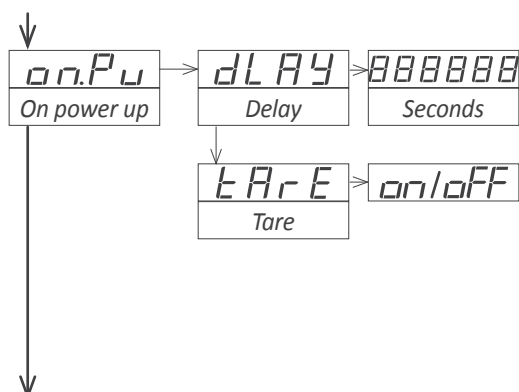

The **'On power up' ('on.Pu)'** menu assigns functions to apply when the instrument restarts after a power loss. See section 1.12.14 for additional information.

- at the **'Delay' ('dLAY)'** parameter configure the time the instrument waits before starting normal operation. Value between 0 and 200 seconds.
- at the **'tare' ('tArE)'** parameter configure to 'on' to activate a tare every time the instrument restarts after a power loss.

1.12.17 Tools

The 'Tools' ('tool') menu groups functions with a variety of uses.

- at the 'Password' ('PASS') function define a 6 digit code to block access to the 'configuration menu'. Activate the password to prevent access to the instrument configuration by non authorized personnel. To activate the 'Password' function select 'on' and enter the code.

The numerical code is asked when accessing the 'configuration menu' (key'SQ' (■)). Functions configured to be accessible through the 'fast access' menu are not 'Password' blocked.

- at the 'Factory configuration' ('Fact') select 'yes' to activate the default factory configuration (see section 1.14 for a list of default parameters). The cell configuration parameters ('Initial conf.' ('Init') menu) are not affected by this reset if the 'Reset 'initial conf.' ('F.Inl') parameter is 'off'.

- at the 'Reset 'initial conf.' ('F.Inl') parameter select 'on' to include the cell configuration parameters when activating the default factory configuration.



The factory reset applied to the 'initial configuration' parameters affects the cell configuration parameters. For a correct reading, a new cell configuration must be applied, as indicated in section 1.12.2.

- the 'Version' ('VEr') parameter informs about the firmware version loaded on the instrument.

- At the 'Brightness' ('LIGH') parameter select the intensity of the display brightness. Five levels available. With this function the instrument brightness can be adapted to match the brightness of nearby instruments.

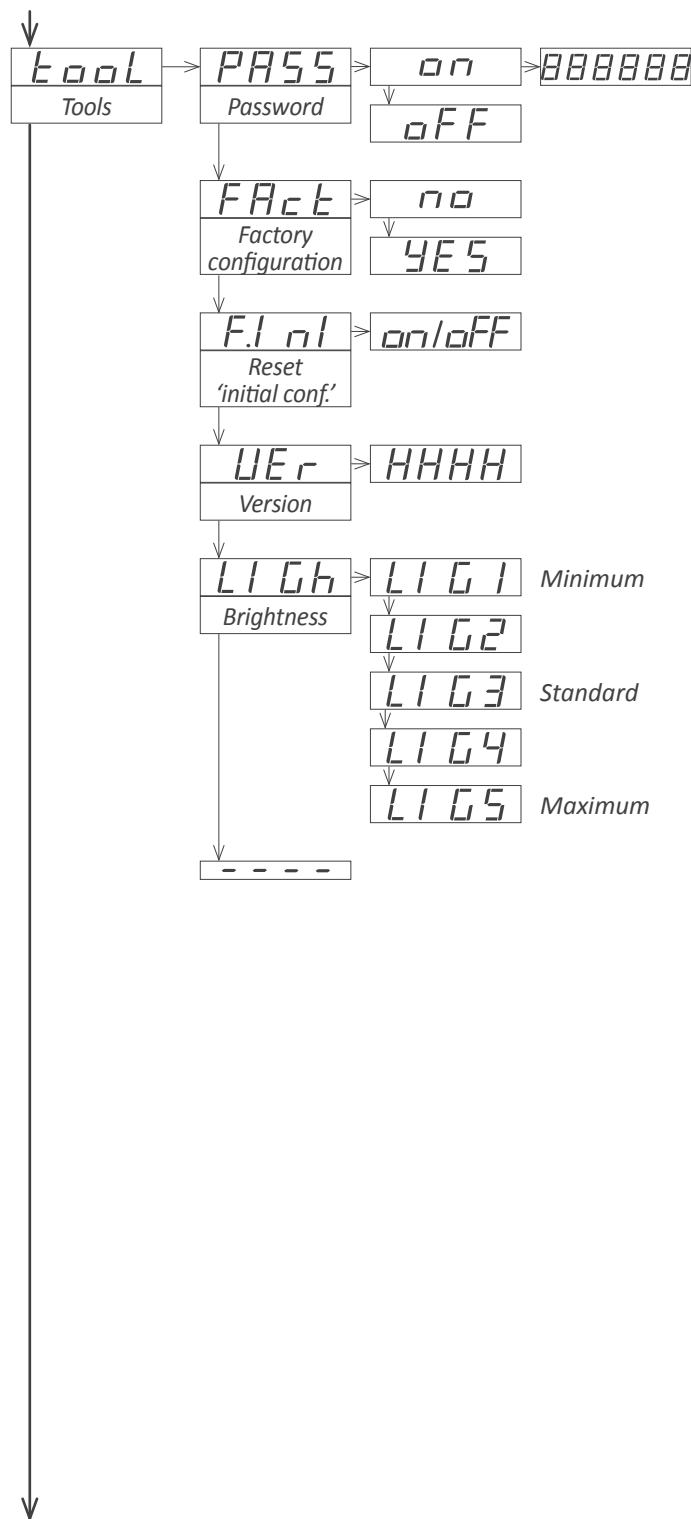

1.12.18 Access to options configurations menu

The 'Opt.1', 'Opt.2' and 'Opt.3' menu entries give access to the configuration menus for the optional modules installed at Opt.1, Opt.2 and Opt.3 slots.

See section 2 for a list of the different modules available that can be installed on each slot. The configuration menu for each module is described at the User's Manual of each module.

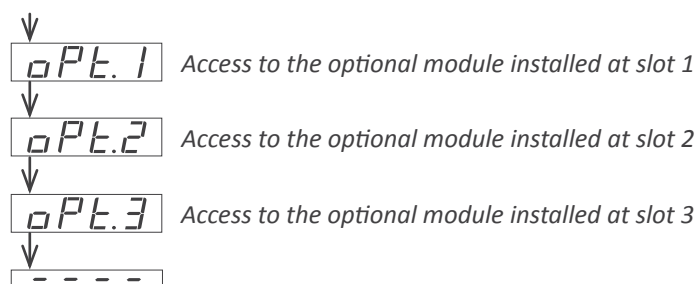

This page blank

1.13 Full configuration menu

Press 'SQ' (■) for 1 second to access the 'configuration menu'.

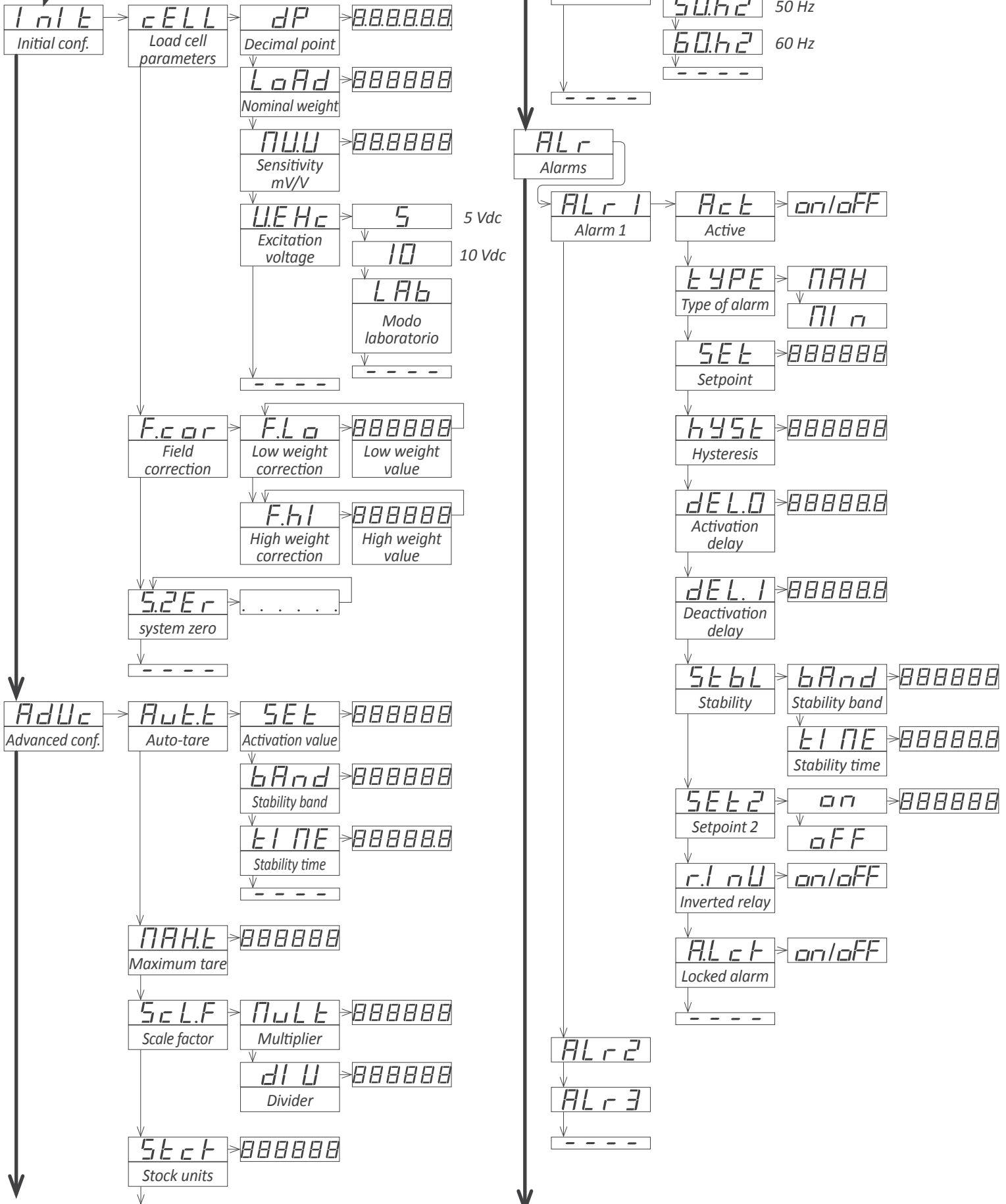

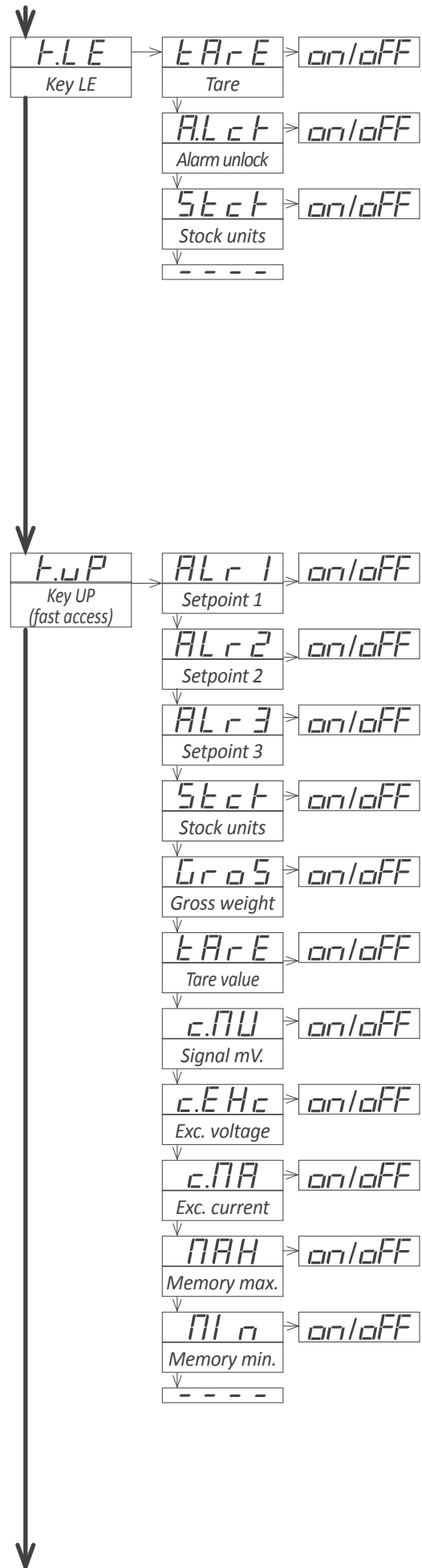
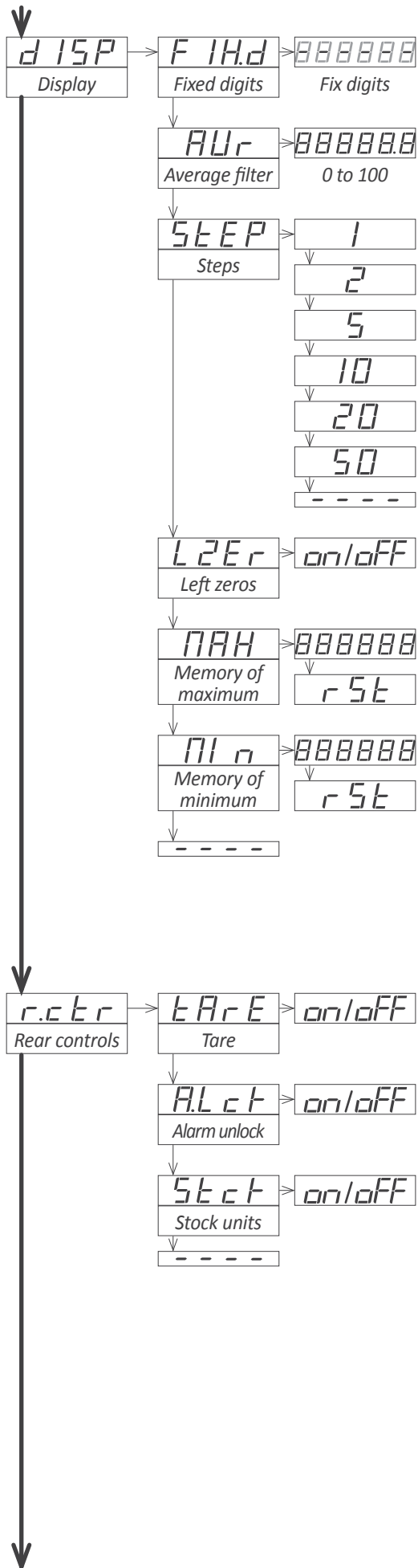

1.14 Full configuration menu (cont)

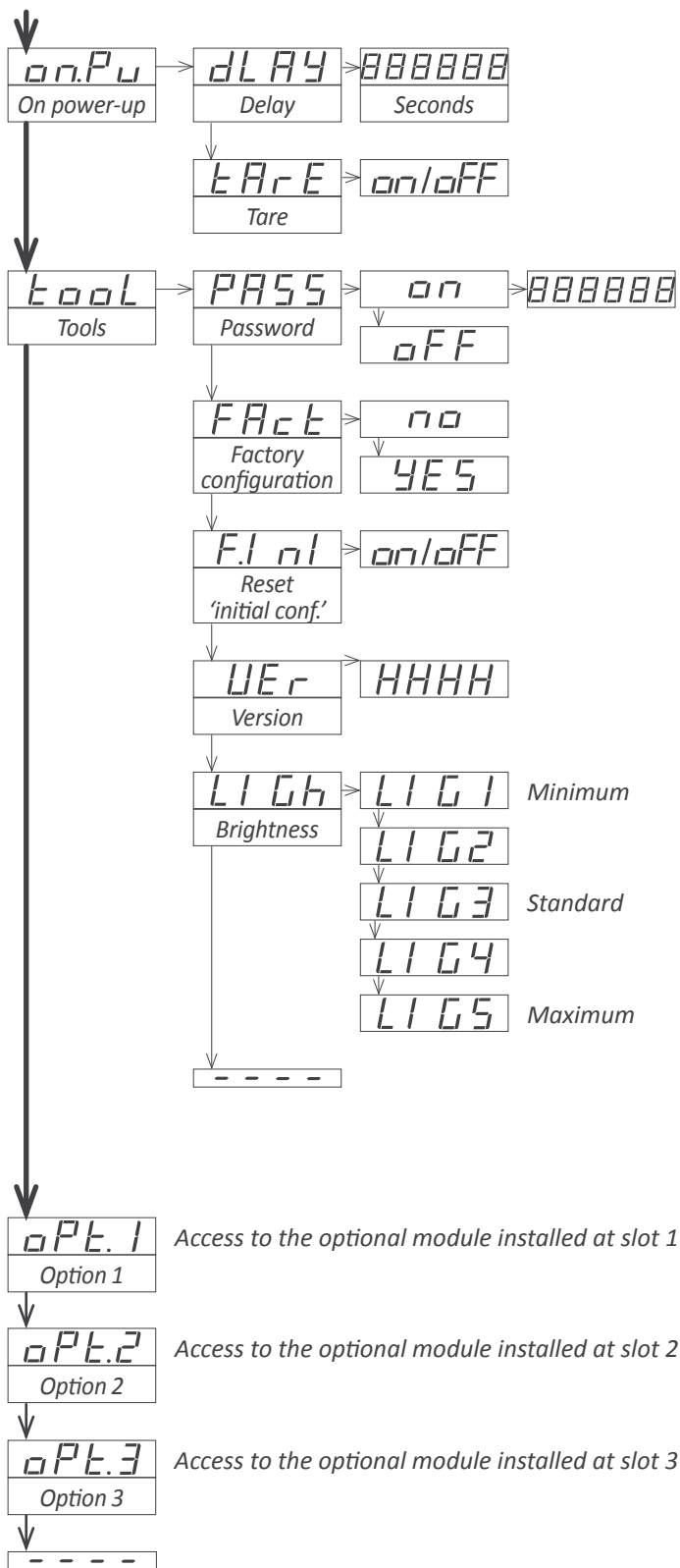

1.14 Factory configuration

Initial configuration ('InIt')	
Load cell parameters ('cELL')	
Decimal point ('dP')	without (XXXXXX)
Sensitivity mV/C ('MV.V')	2.0000
Nominal weight('LoAd')	200000
Excitation voltage ('V.Exc')	10 Vdc ('10')
Advanced configuration ('AdvC')	
Auto-tare ('Aut.t')	
Activation value('SEt')	10
Stability band ('bAnd')	0 (disabled)
Stability time ('tIME')	0.0 (disabled)
Maximum tare ('MAX.t')	999999
Scale factor ('ScL.F')	
Multiplier ('MuLt')	1
Divider('dIV')	1
Stock units ('Stck')	0 (disabled)
Mode ('ModE')	standard ('Std')
Alarms 1,2 and 3 ('ALr.1', 'ALr.2', 'ALr.3')	
Active ('Act')	off (disabled)
Type ('tYPE')	maximum ('MAX')
Setpoint ('SEt')	1000
Hysteresis ('hYSt')	0 counts
Activation delay ('dEL.0')	0.0 seconds
Deactivation delay ('dEL.1')	0.0 seconds
Stability ('StbL')	
Stability band ('bAnd')	10 counts
Stability time ('tIME')	0.0 (disabled)
Setpoint 2 ('SEt.2')	off (disabled)
Inverted relay ('r.InV')	off
Locked alarms ('A.LcK')	off
Display ('dISP')	
Fixed digits ('FIX.d')	no fixed digits ('-----')
Average filter('AVr')	0 (disabled)
Steps ('StEP')	1
Left zeros ('LZEr')	off
Memory of maximum ('MAX')	-199999
Memory of minimum ('MIn')	999999
Rear controls ('r.ctr')	
all	'off'
Key LE ('K.LE')	
Tare	on
Alarm unlock	off
Stock units	off
Key UP ('K.uP')	
all	'off'
On power up	
Delay	0
Tare	off
Tools	
Password ('PASS')	off
Reset 'initial conf.'('F.Ini')	off
Brightness ('LIGH')	3

1.15 Messages and errors

Error messages are informed flashing on display.

<i>Messages and errors</i>	
'd.udr' 'd.ovr'	display underrange ('d.udr')/overrange ('d.ovr'). The display is already reading the minimum/maximum value possible (-199999/999999).
'Err.0'	incorrect scaling (vertical slope)
'Err.1'	incorrect password.
'Err.2'	when accessing an 'oPt.X' menu entry, there is no recognize module installed.
'Err.6'	in 'stock units' mode, weight value is 0 and can not be assigned to a quantity of units.
'Err.8'	over current at the excitation voltage.
'----'	requested reading is not accessible (reading of units with the 'stock units' mode disabled).

Table 6 - Messages and error codes

1.16 Practical cases

1.16.1 Normal case

Case for 1 load cell, powered from the instrument, with power 10Vdc, nominal weight 100Kg and 2 mV/V sensibility.

- Connect the load cell to the instrument (see section 1.8).
- Configure the 'theoretical configuration of the load cell' (see section 1.12.2).
- Apply the 'empirical configuration of the load cell' (see section 1.12.2).
- Configure the 'system zero' (see section 1.12.2).

Depending on the specifications of your load cell, you may need to apply a 'tare' each time that the weight is removed from the load cell. See at section 1.11 the different options available to activate the 'tare' function.

1.16.2 Load cell with external power

Case for 1 load cell, with external power.

- Connect the load cell normally, and **do not** connect 'Vexc+'. Connect 'Sense+' and 'Sense-' to the load cell. 'Vexc-' must be connected to 'Sense-'. See Figure 9.
- Configure the 'theoretical configuration of the load cell' (see section 1.12.2). The value assigned to Vexc does not affect the measure.
- Apply the 'empirical configuration of the load cell' (see section 1.12.2).
- Configure the 'system zero' (see section 1.12.2).

Depending on the specifications of your load cell, you may need to apply a 'tare' each time that the weight is removed from the load cell. See at section 1.11 the different options available to activate the 'tare' function.

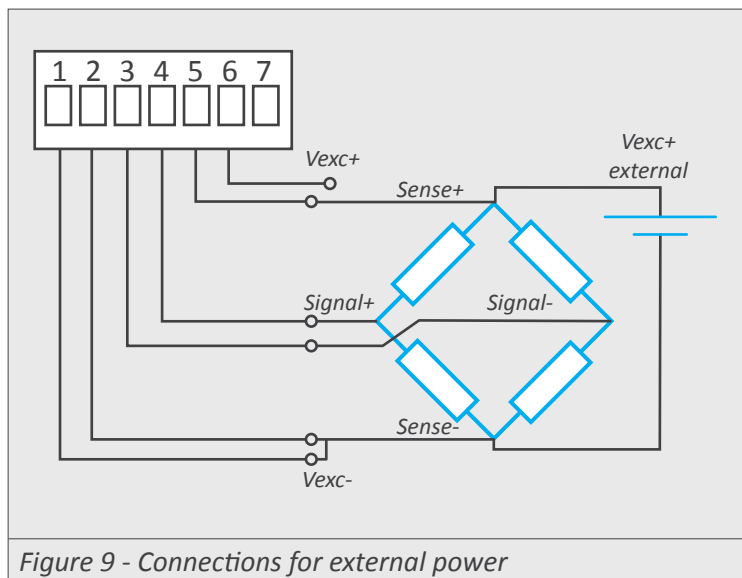

Figure 9 - Connections for external power

1.16.3 Connections with a junction box



A 'junction box' for load cells has internal electronics that can modify the 'signal/weight' relation provided to the instrument. Check the manufacturer documentation of the junction box.

Case for 4 load cells connected to a 'junction box'. It is assumed that the 'junction box' is used as a simple 'connections box'. All 4 load cells are the same type of load cell, with nominal weight of 100 Kg and 2 mV/V sensibility.

- Connect the 4 load cells to the 'junction box'. Connect the instrument to the 'junction box' using 4 or 6 wires, as indicated in the 'junction box' documentation. If 4 wires 'junction box' is used, see section 1.8.1 to connect the 'sense' wires not used ('sense' wires must connected).
- Configure the 'theoretical configuration of the load cell' (see section 1.12.2). Take note that the sensitivity of the system remains the same (2 mV/V) and the nominal weight of the system is the addition of the nominal weight of each cell (4 x 100 Kg = 400 Kg)
- Apply the 'empirical configuration of the load cell' (see section 1.12.2).
- Configure the 'system zero' (see section 1.12.2).

Depending on the specifications of your load cell, you may need to apply a 'tare' each time that the weight is removed from the load cell. See at section 1.11 the different options available to activate the 'tare' function..

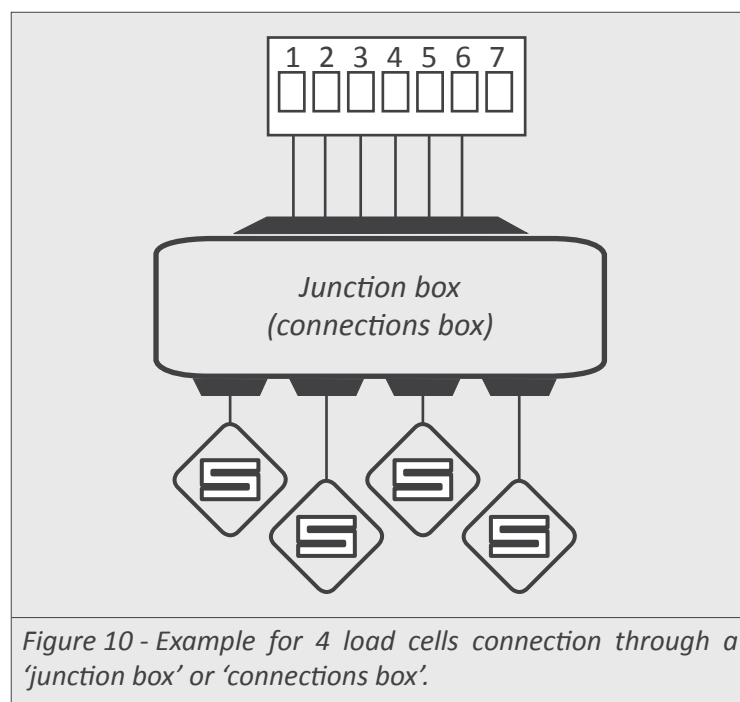

Figure 10 - Example for 4 load cells connection through a 'junction box' or 'connections box'.

1.16 Practical cases (cont.)

1.16.4 Connections with 3 or 4 load cells

Using 3 load cells is the optimal way to distribute the weight on a plane, although it is common to work with 4 load cells, in applications with tanks, hoppers and similar.

When working with multiple load cells, the optimal connection is the one that makes the wires of the cell converge in the same central area, so that all the cells are at the same 'electrical distance' from the meter.

Use the same type load cell (for example, load cells with nominal load of 100Kg and sensitivity of 2 mV/V) and connect the wires to the central area as indicated below. Configure the instrument as indicates in this manual, assuming that :

- the sensitivity of the system remains the same (2 mV/V)
- the nominal weight of the system is the addition of the nominal weight of each cell (3 x 100 Kg = 300 Kg for 3 cells or 4 x 100 Kg = 400 Kg for 4 cells)
- the 'sense' wires are carried to the central zone together with the Vexc wires, but are not propagated to each individual cell. If you do not want to use the 'sense' wires, see section 1.8.1.

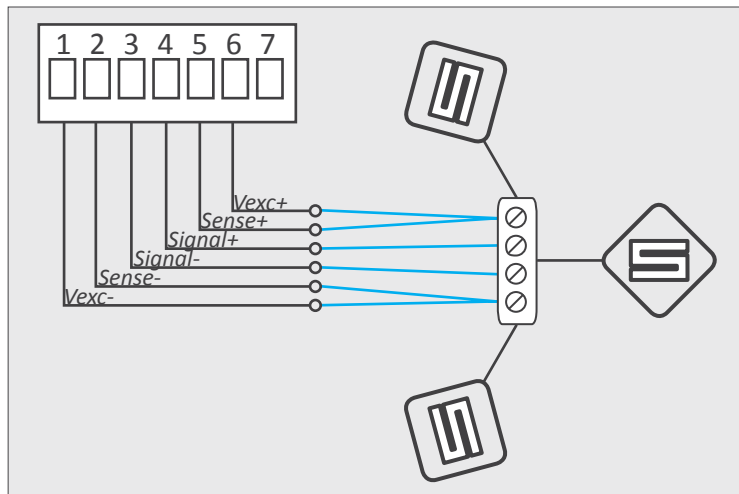

Figure 11 - Connection example with 3 load cells.

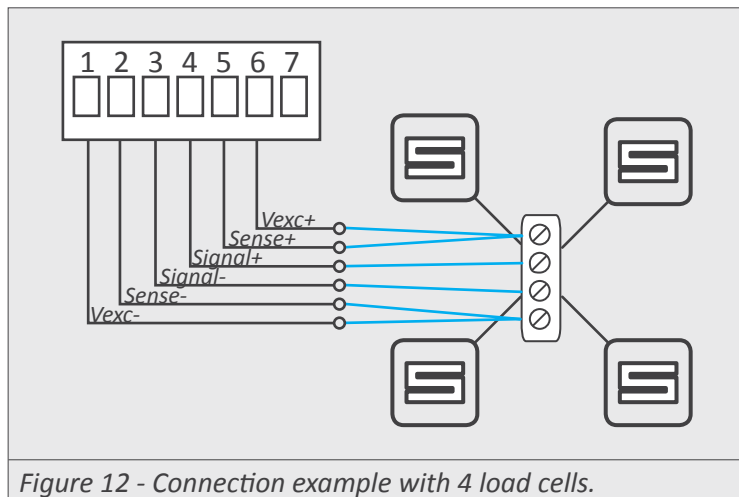

Figure 12 - Connection example with 4 load cells.

1.16.5 Measuring mV at the laboratory

If you wish to configure the instrument to measure a millivolt generated signal at the laboratory, there is a special configuration to apply. Different from the load cell, the millivolt generator is not a differential system, and does not need excitation voltage.

- Connect the instrument to the millivolt meter (see Figure 13). Add 2 resistances of 10 KOhm to connect the 'Vexc' terminals to the common of the signal generator.
- Inside the 'configuration menu', select the 'Vexc' parameter to 'Lab' (see section 1.12.2). This value deactivates the ratiometric measurement and activates the direct millivolt measurement.
- At the additional parameters at the 'theoretical configuration of the load cell' (see section 1.12.2) assign the desired reading and the mV/V parameter. Note that values of 1 mV/V, 2 mV/V and 3 mV/V will activate a full scale range of 10 mV, 20 mV and 30 mV respectively.
- **Do not** apply the 'empirical configuration of the load cell' (see section 1.12.2). Applying this characterization to the signal generator will only generate a reduction in the measurement accuracy.
- Configure the 'system zero' (see section 1.12.2). This step is needed for a correct mV measurement. Generate 0 mV and 'assign the system zero'.



To reduce leak currents that can affect the laboratory measurement:

1. if the millivolt generator is powered from the mains network, use an isolator transformer to power the generator
2. if the instrument is powered from the mains network, use a separate isolator transformer to power the instrument

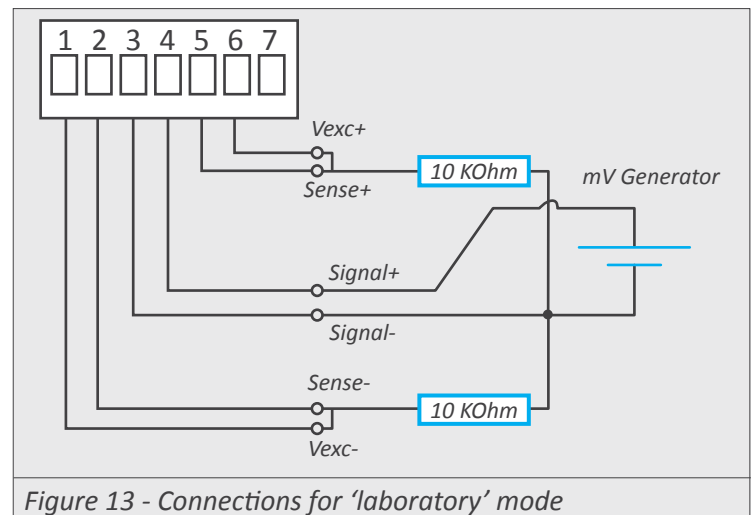
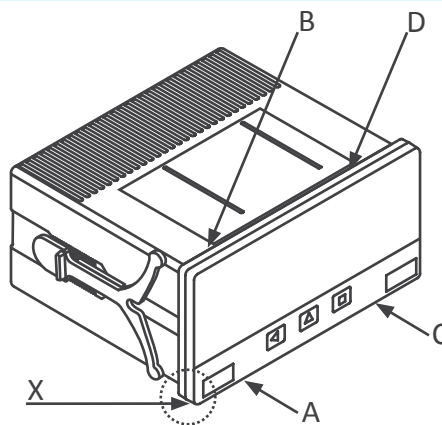

Figure 13 - Connections for 'laboratory' mode

1.17 To access the instrument

To open the housing and access the internal circuits, use a flat screwdriver to unlock clips 'D', 'C', 'B' and 'A', in this order. Remove the front filter. Let the inside of the instrument slide out of the housing.

To reinsert the instrument make sure that all modules are correctly connected to the pins on the display module. Place all the set into the housing, assuring that the modules correctly fit into the internal guiding slides of the housing. Once introduced, place again the front filter at corner 'X', and then insert clips 'A', 'B', 'C' and 'D', in this order.



Risk of electric shock. Removing the front cover will grant access to the internal circuits. Disconnect the input signal to prevent electric shock to the operator. Operation must be performed by qualified personnel only.



Observe precautions for handling ESD (electrostatic discharge) sensitive devices

1.18 Modular architecture

Series M panel meter are designed based on a modular architecture. This modularity allows to replacement, change or add any of the internal modules conforming the instrument.

Below is a graphical explanation of the location of each module.

See section 2 for a list of optional modules available.

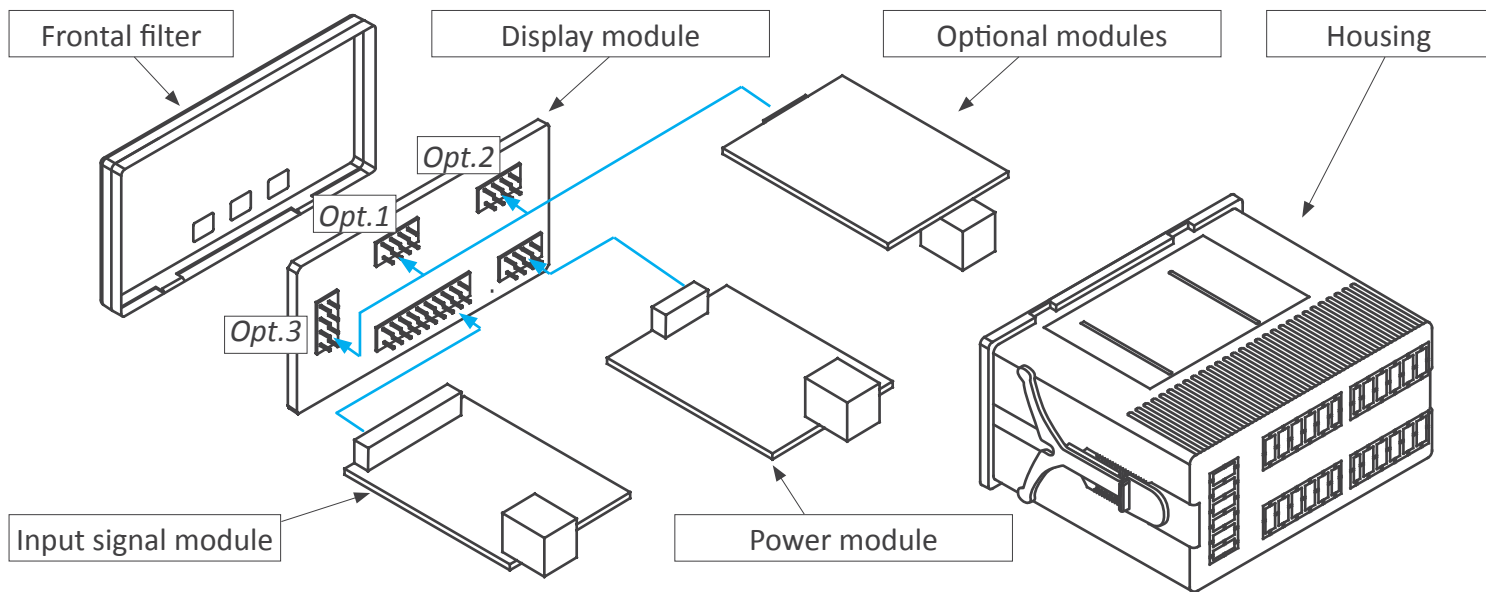

How to Install in a panel

1. Remove the 2 blue plastic tabs from each side of the unit.
2. Insert instrument from the front of panel into panel cut out.
3. Re-attach the 2 blue plastic tabs by sliding each one into the track opening on each side and push until the tabs grab onto the notches until snug onto the back of panel.

If needed use a flat screw driver to push the tabs strongly like in the image (A).

To uninstall the instrument, just place the screw driver and turn it between the box and the tab to ungrab the tabs (B).

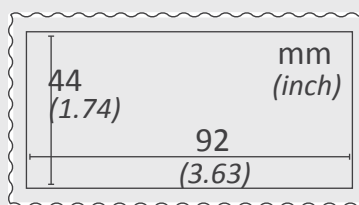

Panel cut-out

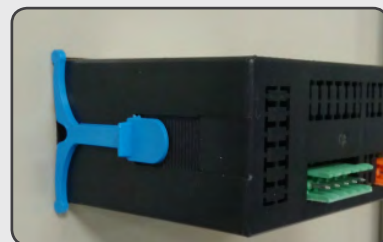

1.19 Precautions on installation



Risk of electrical shock. Instrument terminals can be connected to dangerous voltage.



Instrument protected with double isolation. No earth connection required.



Instrument conforms to CE rules and regulations.

This instrument has been designed and verified conforming to the 61010-1 CE Security Regulation, for industrial applications.

Installation of this instrument must be performed by qualified personnel only. This manual contains the appropriate information for the installation. Using the instrument in ways not specified by the manufacturer may lead to a reduction of the specified protection level. Disconnect the instrument from power before starting any maintenance and / or installation action.

The instrument does not have a general switch and will start operation as soon as power is connected. The instrument does not have protection fuse, the fuse must be added during installation.

The instrument is designed to be panel mounted. An appropriate ventilation of the instrument must be assured. Do not expose the instrument to excess of humidity. Maintain clean by using a humid rag and do NOT use abrasive products such as alcohols, solvents, etc.

General recommendations for electrical installations apply, and for proper functionality we recommend : if possible, install the instrument far from electrical noise or magnetic field generators such as power relays, electrical motors, speed variators, ... If possible, do not install along the same conduits power cables (power, motor controllers, electrovalves, ...) together with signal and/or control cables.

Before proceeding to the power connection, verify that the voltage level available matches the power levels indicated in the label on the instrument.

In case of fire, disconnect the instrument from the power line, fire alarm according to local rules, disconnect the air conditioning, attack fire with carbonic snow, never with water.

1.20 Warranty

This instrument is warranted against all manufacturing defects for a period of 24 months, as requested by the European legislation. This warranty does not apply in case of misuse or accident, and the scope of the warranty is limited to repair of the instrument, not being the manufacturer responsible for additional damages or additional costs. Within the warranty period and after examination by the manufacturer, the unit will be repaired or substituted when found to be defective.

1.21 CE declaration of conformity

Manufacturer FEMA ELECTRÓNICA, S.A.
 Altimira 14 - Pol. Ind. Santiga
 E08210 - Barberà del Vallès
 BARCELONA - SPAIN
 www.fema.es - info@fema.es

Product M60-LC

The manufacturer declares that the instruments indicated comply with the directives and rules indicated below.

Electromagnetic compatibility directive 2014/30/EU

Low voltage directive 2014/65/EU

Directive ROHS 2011/65/EU

Security rules EN-61010-1

Instrument Fixed
 Permanently connected
 Degree of pollution 1 and 2 (without condensation)
 Isolation Double

Electromagnetic compatibility rules EN-61326-1

EM environment Industrial

Immunity levels

EN-61000-4-2 By contact ± 4 KV Criteria B
 By air ± 8 KV Criteria B

EN-61000-4-3 Criteria A

**use shielded cable for signal and power lines to assure compliance with the rule.*

EN-61000-4-4 On AC power lines: ± 2 KV Criteria B
 On DC power lines: ± 2 KV Criteria B
 On signal lines : ± 1 KV Criteria B

EN-61000-4-5 Between AC power lines ± 1 KV Criteria A
 Between DC power lines DC ± 0.5 KV Criteria A

EN-61000-4-6 Criteria A

**maintain signal and control lines below 3 meter length to assure compliance with the rule.*

EN-61000-4-8 30 A/m a 50/60 Hz Criteria A

EN-61000-4-11 0 % 1 cycle Criteria A
 40 % 10 cycles Criteria A
 70 % 25 cycles Criteria B
 0 % 250 cycles Criteria B

Emission levels

CISPR 11 Instrument Class A, Group 1 Criteria A

Barberà del Vallès, February 2018

Xavier Juncà - Product Manager



According to directive 2012/19/EU, electronic equipment must be recycled in a selective and controlled way at the end of its useful life.

2. Output and control modules

2.1 Module R1

The R1 module provides 1 relay output, to install on Series M meters, up to a maximum of 3 relay outputs in the same meter (for more than 3 relays, see special modules R2, R4 and R6 at section 2.8).

Configuration from the front key pad, through the alarms menu of each instrument. For more information see the 'alarm' section at the user's manual.

Relay with 3 contacts (common, normally closed, normally open) switching up to 250V @8A.

The R1 modules can be supplied already installed into a Series M panel meter or as a standalone module. The installation requires no soldering or special configuration.

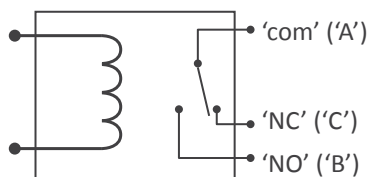
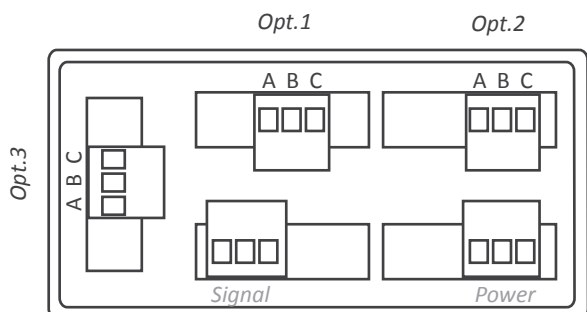

Figure 14 - Detail of the 'R1' module and internal scheme

Type of relay	3 contacts (Com, NO, NC)
Max. current	8 A (resistive load)
Voltage	250 Vac continuous
Isolation	3500 Veff
Type of terminal	plug-in screw terminal, pitch 5.08 mm
Installation allowed at	Opt.1, Opt.2, Opt.3



A	Common
B	NO (Normally Open)
C	NC (Normally Closed)

Figure 15 - Connections for 'R1' relay module

For additional information:
http://fema.es/docs/4254_SERIES_M-K-S_OPTIONS_manual_en.pdf

2.2 Module T1

The T1 module provides 1 transistor output, to install on Series M meters, up to a maximum of 3 transistor outputs in the same meter.

Configuration from the front key pad, through the alarms menu of each instrument. For more information see the 'alarm' section at the user's manual.

Optocoupled output, 2 terminals, switching up to 35V @50mA.

The T1 modules can be supplied already installed into a Series M panel meter or as a standalone module. The installation requires no soldering or special configuration.

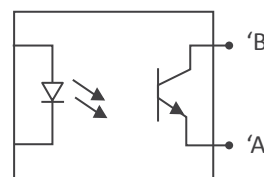
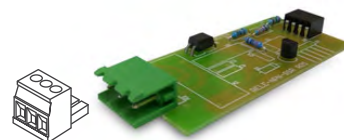
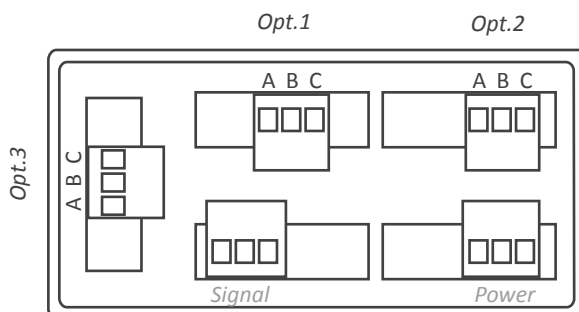

Figure 16 - Detail of the 'T1' module and internal scheme

Type of output	transistor
Max. voltage	35 Vdc
Max. current	50 mA
Isolation	3500 Veff
Type of terminal	plug-in screw terminal, pitch 5.08 mm
Installation allowed at	Opt.1, Opt.2, Opt.3



A	Emitter
B	Collector
C	Not connected

Figure 17 - Connections for 'T1' transistor module

For additional information:
http://fema.es/docs/4254_SERIES_M-K-S_OPTIONS_manual_en.pdf

2.3 Module SSR

The SSR module provides 1 output to control an SSR relay, to install on Series M meters, up to a maximum of 3 SSR outputs in the same meter.

Configuration from the front key pad, through the alarms menu of each instrument. For more information see the 'alarm' section at the user's manual.

2 terminal output, with +15V @45mA drive.

The SSR modules can be supplied already installed into a Series M panel meter or as a standalone module. The installation requires no soldering or special configuration.

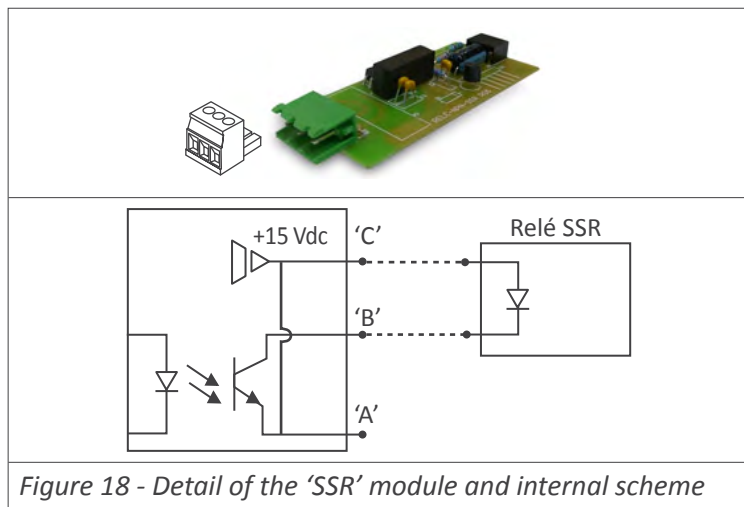

Figure 18 - Detail of the 'SSR' module and internal scheme

Type of output	to control and SSR relay
Voltage output	15 Vdc
Max. current	45 mA
Isolation	3500 Veff
Type of terminal	plug-in screw terminal, pitch 5.08 mm
Installation allowed at	Opt.1, Opt.2, Opt.3

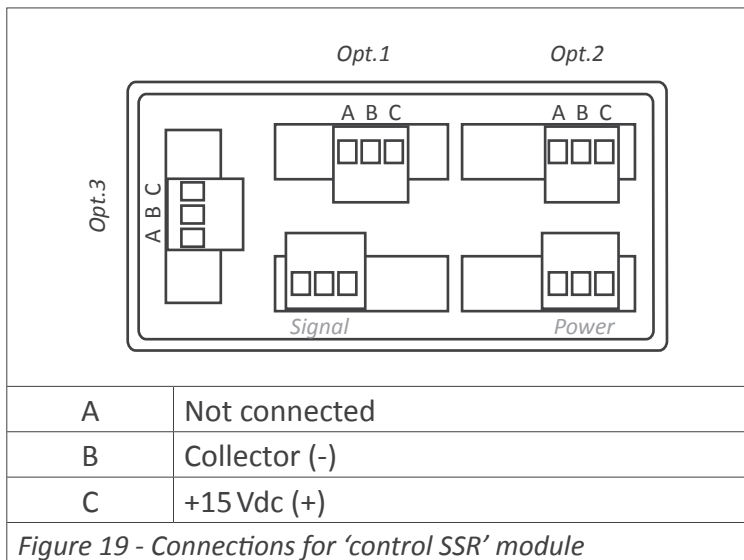

Figure 19 - Connections for 'control SSR' module

For additional information:
http://fema.es/docs/4254_SERIES_M-K-S_OPTIONS_manual_en.pdf

2.4 Module AO

The AO module provides 1 isolated analog output, configurable for 4/20 mA or 0/10 Vdc, to install on Series M meters, up to a maximum of 3 analog outputs in the same meter. Output signal is fully scalable, both with positive and negative slopes, and is proportional to the reading.

The mA output can be configured for active loops (the instrument provides the power to the mA loop) or passive loops (the loop power is external to the instrument).

Configuration from the front key pad, through the 'Opt.1', 'Opt.2' or 'Opt.3' menu entries, depending on the slot where the module is installed.

The AO modules can be supplied already installed into a Series M panel meter or as a standalone module. The installation requires no soldering or special configuration.

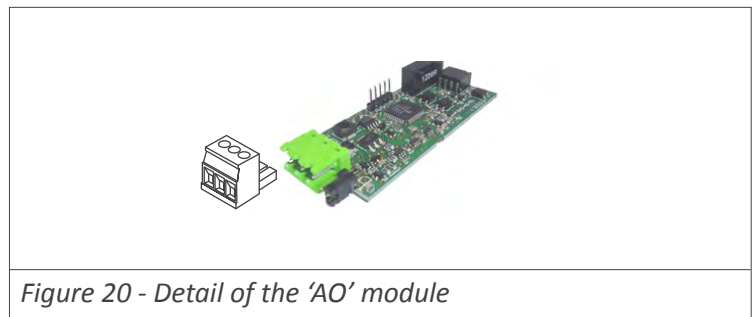

Figure 20 - Detail of the 'AO' module

Output signal	4/20mA, 0/10Vdc (active and passive)
Accuracy	0.1% FS
Isolation	1000 Vdc
Type of terminal	plug-in screw terminal, pitch 5.08 mm
Installation allowed at	Opt.1, Opt.2, Opt.3

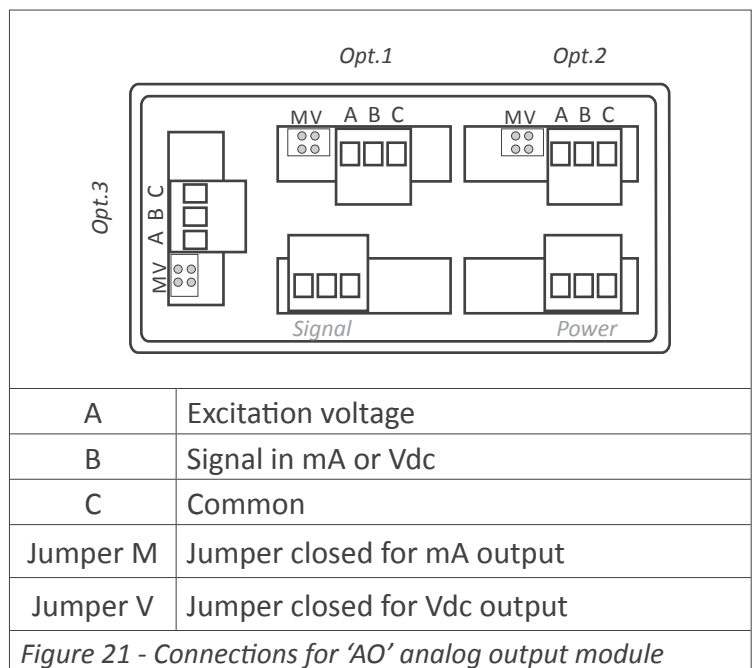

Figure 21 - Connections for 'AO' analog output module

For additional information:
http://fema.es/docs/4254_SERIES_M-K-S_OPTIONS_manual_en.pdf

2.5 Module RTU

The RTU module provides 1 isolated RS-485 Modbus RTU output, to install on Series M meters.

The module implements function 4 (*Read Input Registers*) of the Modbus RTU protocol, to access the instrument registers (display values, alarm status, memory of maximum and minimum, etc).

Configuration from the front key pad, through the 'Opt.1', 'Opt.2' or 'Opt.3' menu entries, depending on the slot where the module is installed.

The RTU modules can be supplied already installed into a Series M panel meter or as a standalone module. The installation requires no soldering or special configuration.



Figure 22 - Detail of the Modbus 'RTU' communications module

Protocol	Modbus RTU
Type of bus	RS-485, up to 57.6 Kbps
Isolation	1000 Vdc
Type of terminal	plug-in screw terminal, pitch 5.08 mm
Installation allowed at	Opt.1, Opt.2, Opt.3

2.6 Module S4

The S4 module provides 1 isolated RS-485 ASCII output, to install on Series M meters.

The protocol implements a MASTER / SLAVE architecture, addressable with up to 31 slave modules. The slave mode allows access to the instrument registers (display values, alarm status, memory of maximum and minimum, etc).

It allows to repeat the reading to remote large format meters from series B (model Bxx-485, with 60mm and 100mm digit height),

Configuration from the front key pad, through the 'Opt.1', 'Opt.2' or 'Opt.3' menu entries, depending on the slot where the module is installed.

The S4 modules can be supplied already installed into a Series M panel meter or as a standalone module. The installation requires no soldering or special configuration.



Figure 24 - Detail of the 'S4' RS-485 communications module

Protocol	ASCII
Type of bus	RS-485, up to 57.6 Kbps
Isolation	1000 Vdc
Type of terminal	plug-in screw terminal, pitch 5.08 mm
Installation allowed at	Opt.1, Opt.2, Opt.3

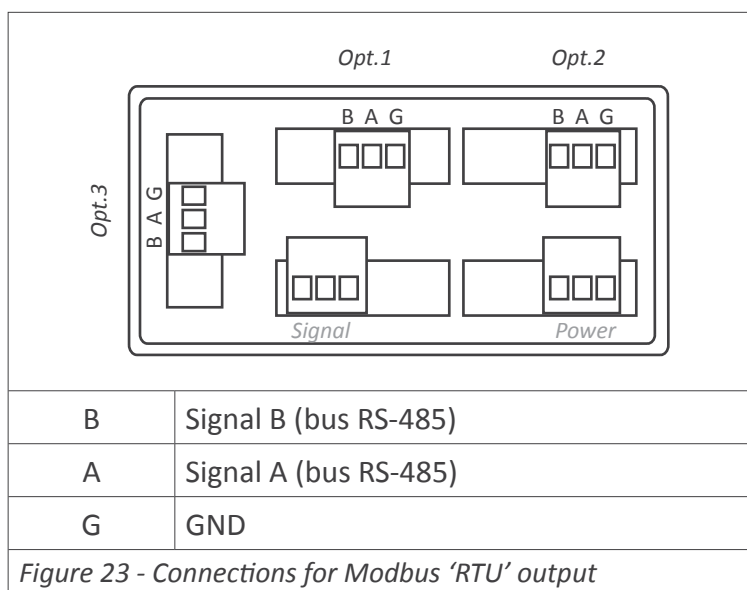

Figure 23 - Connections for Modbus 'RTU' output

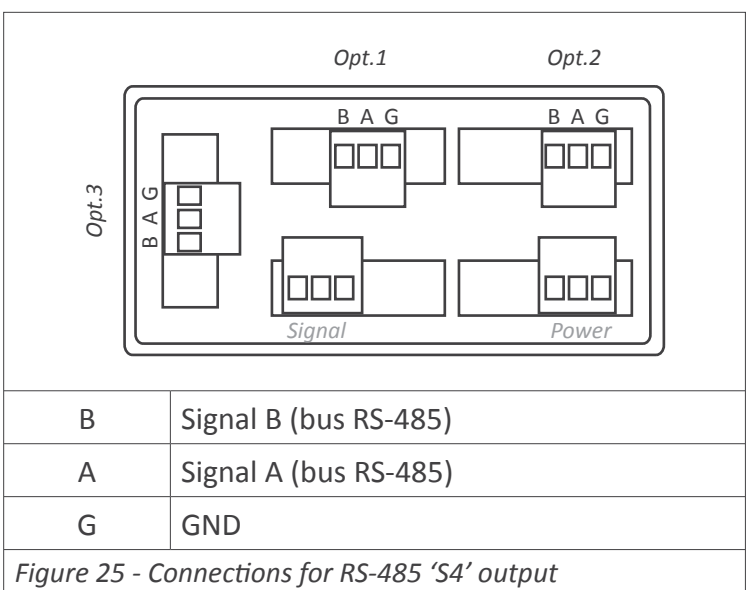

Figure 25 - Connections for RS-485 'S4' output

2.7 Module S2

The S2 module provides 1 isolated RS-232 ASCII output, to install on Series M meters.

The protocol implements a MASTER / SLAVE architecture, addressable with up to 31 slave modules. The slave mode allows access to the instrument registers (display values, alarm status, memory of maximum and minimum, etc).

Configuration from the front key pad, through the 'Opt.1', 'Opt.2' or 'Opt.3' menu entries, depending on the slot where the module is installed.

The S2 modules can be supplied already installed into a Series M panel meter or as a standalone module. The installation requires no soldering or special configuration.

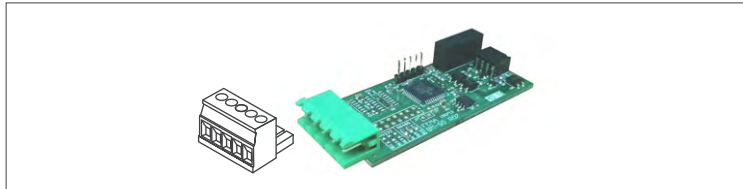
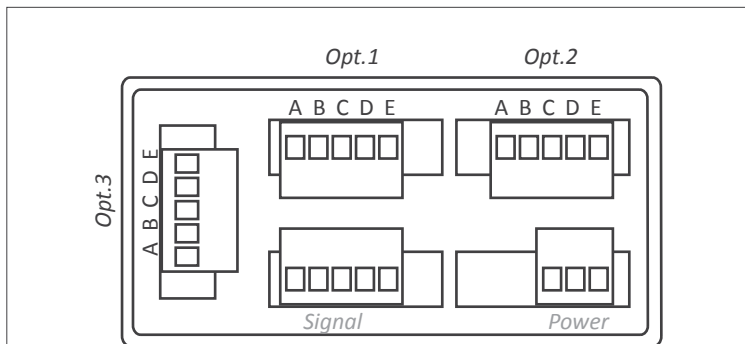

Figure 26 - Detail of the 'S2' RS-232 communications module

Protocol	ASCII
Type of bus	RS-232, up to 57.6 Kbps
Isolation	1000 Vdc
Type of terminal	plug-in screw terminal, pitch 5.08 mm
Installation allowed at	Opt.1, Opt.2, Opt.3



A	Wire Tx for 'daisy-chain' data transmission
B	Wire Rx for 'daisy-chain' data reception
C	Wire Tx for data transmission
D	Wire Rx for data reception
E	GND

Figure 27 - Connections for RS-232 'S2' output

For additional information:
http://fema.es/docs/4254_SERIES_M-K-S_OPTIONS_manual_en.pdf

2.8 Modules R2, R4, R6

Special modules R2, R4 and R6 offer 2, 4 and 6 relay outputs, to install on Series M meters.

Configuration from the front key pad, through the 'Opt.1' menu entry.

Modules R2, R4 and R6 are not compatible between them and can not be mounted together with R1, T1 or SSR modules. Installing a R2, R4 or R6 module disables the alarm menus AL1, AL2 and AL3 of the instrument.

Choose special modules R2, R4 or R6 when a higher density of relays is needed.

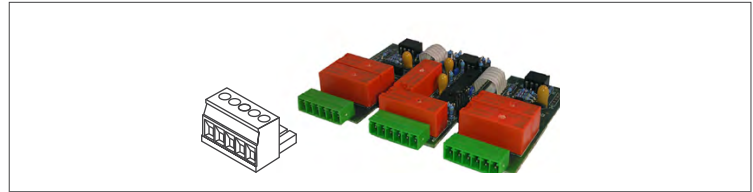
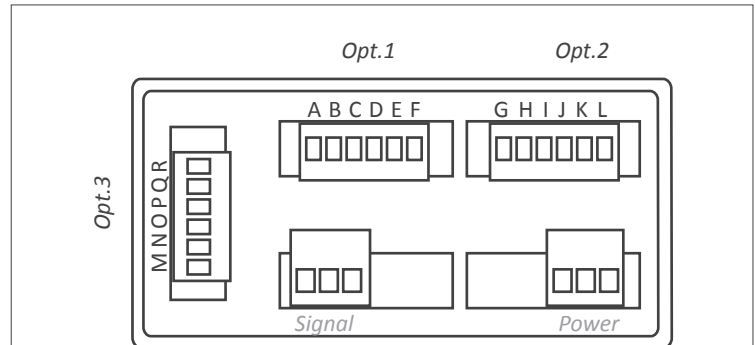

Figure 28 - Detail of an 'R6' module

Type of relay	3 contacts (Com, NO, NC)
Max. current	6 A (resistive load) (each relay)
Max. voltage	250 Vac continuous
Isolation	2500 Veff
Type of terminal	plug-in screw terminal, pitch 3.81 mm
* terminals approved for 300 V (UL1059, groups B and D) and 160 V (VDE with CAT-III and pollution degree 3).	
Module R2	fills Opt.1
Module R4	fills Opt.1 and Opt.2
Module R6	fills Opt.1, Opt.2 and Opt.3



	Common	Norm open (NO)	Norm. closed (NC)
relay 1	A	B	C
relay 2	D	E	F
relay 3	G	H	I
relay 4	J	K	L
relay 5	M	N	O
relay 6	P	Q	R

Figure 29 - Connections for modules 'R2', 'R4' and 'R6'

For additional information:
http://fema.es/docs/4254_SERIES_M-K-S_OPTIONS_manual_en.pdf

3. Other options

3.1 Option NBT

Instruments without front keypad. To configure the instrument, remove the meter from the panel and remove the front filter. Internal press buttons for configuration are accessible. Optionally, request the instrument preconfigured from factory.



3.2 Option G

Option with green leds



4. Accessories

4.1 THM benchtop housing

Benchtop housing for Series M, K and C and of panel meters. Handle with three selectable positions. Power connector with manual switch and fuse holder.



4.4 WME wall housing

Wall mount housing. Together with the KIP protector, offers a full IP65 protection. For Series M, K and C of panel meters.



4.2 Adapter DRA-M

Adapter for DIN rail mount, for Series M, K and C



4.5 Protector KIP

Removable front cover for additional mechanical and IP65 front protection, for series M, K and C.



4.3 Adapter KA96

Adapter 96x96 mm for 96x48 mm instruments.





Panel meters
Standard 96x48 mm



Large format meters



Panel meters
Compact 72x36 mm



Bar meters



Signal converters



Panel meters
Miniature 48x24 mm



Isolators



Low Cost



'Customized'
instruments

FEMA

ELECTRÓNICA

FEMA ELECTRÓNICA, S.A.

Altimira 14 - Pol. Ind. Santiga
E08210 Barberà del Vallès
BARCELONA - SPAIN

▪ Tel. +34 93.729.6004

▪ info@fema.es
www.fema.es



Process



Temperature



Counter



Weight



Flow



Time



Frequency



Temperature



Speed



Vac



Aac



Integrators



Potentiometer



Temperature



Period

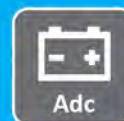

Adc



Vdc



Resistances



Digital

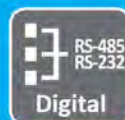

Digital



Digital



Digital

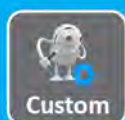

Custom