

### DUAL AXIS INCLINOMETERS

#### DESIGNED TO WITHSTAND HARSH OPERATING CONDITIONS

Those dual axis inclinometers are designed to measure very small changes from the vertical level, either on the ground or in structures.

They exhibit high resolution and low thermal drift. Their mechanical design and enhanced internal surge protection make them particularly useful for the permanent outdoor monitoring of structures being subjected to various influences such as loading and foundation settlement.

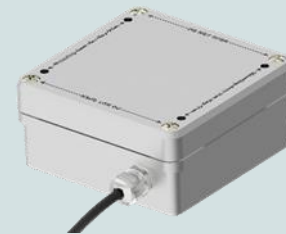
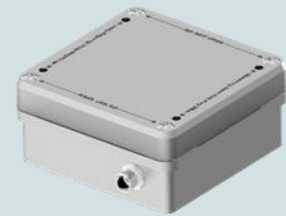

## FIELD OF APPLICATIONS

- Off-shore wind turbine foundations
- Bridges and piers
- Historical buildings
- Structural load testing
- Vessel and pontoon roll and pitch measurement
- Crane roll and pitch measurement
- Structural Health Monitoring

## KEY FEATURES

- Biaxial
- High accuracy and resolution
- Excellent thermal stability
- 4-20 mA current loops for signal immunity and potentially long cable runs
- Enhanced surge protection
- Internal temperature sensor for residual thermal drift compensation
- Two models for horizontal or vertical mounting
- Easy to install

## KEY BENEFITS

- Robustness to environmental conditions
- Short-term or permanent long-term monitoring
- Monitoring of remote areas

## BLOCK DIAGRAM

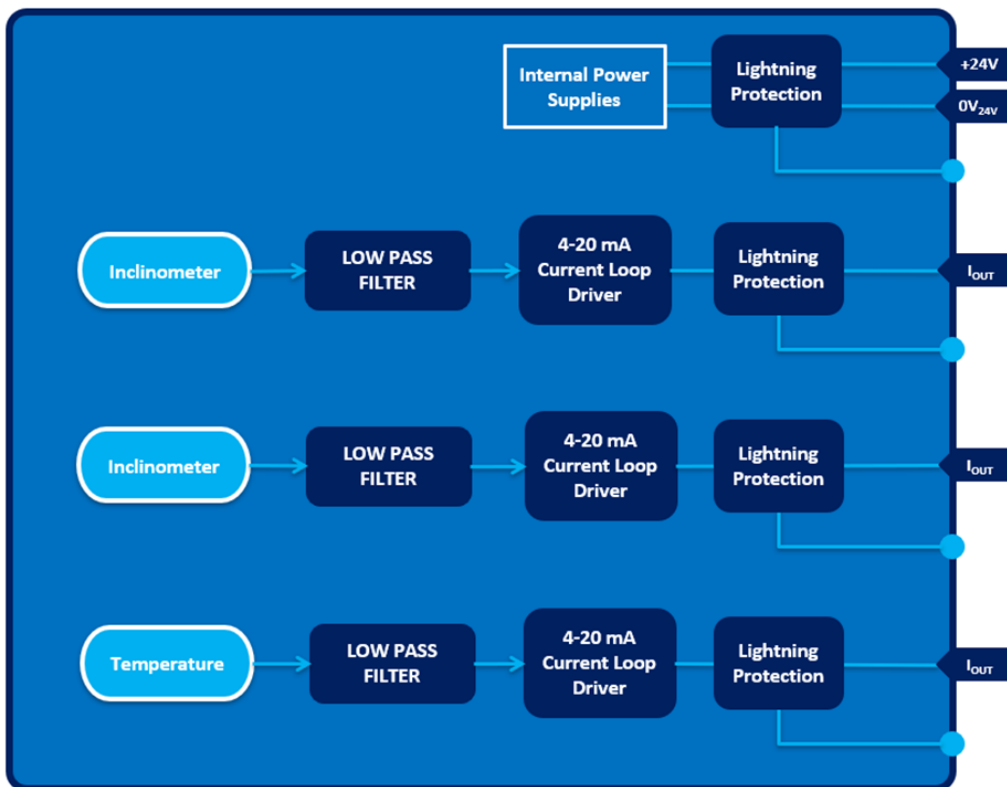

# CHARACTERISTICS

## Tilt angle Channel Characteristics

Parameter	Test Condition	Min.	Typ.	Max.	Unit
Measuring range			±15		°
Sensitivity <sup>(1)</sup>	0...1°		0.555		mA/°
			31.712		mA/g
Sensitivity error			±1		%
Output resolution <sup>(2)</sup>	10Hz BW		0.0015		°
Sensitivity change with Temperature	-25...85°C		±0.015		%/°C
Offset	T° = 25°C	-0.2	0.0	0.2	°
		11.89	12.00	12.11	mA
Offset change with Temperature	-25...85°C		±0.002		°/°C
Non-linearity			±0.06		°
Output noise density	@ 5Hz		0.0005		°/√Hz
Cross Axis Sensitivity			1	4	%
2 <sup>nd</sup> order low-pass filter cutoff frequency	@ -3dB		12		Hz

<sup>(1)</sup> The angle output has SIN curve relationship to current output

<sup>(2)</sup> Resolution = Noise density \* √(bandwidth)

## Temperature Channel Characteristics

Parameter	Test Condition	Min.	Typ.	Max.	Unit
Measurement range		-40		+85	°C
Accuracy	From 0 to 70°C	-0.15		+0.15	°C
	Outside the 0 to 70°C range	-0.50		+0.50	°C
Temperature noise density				0.01	°C/√Hz
2 <sup>nd</sup> order Butterworth low-pass filter cutoff frequency			1		Hz

### Temperature Sensor Response Curve

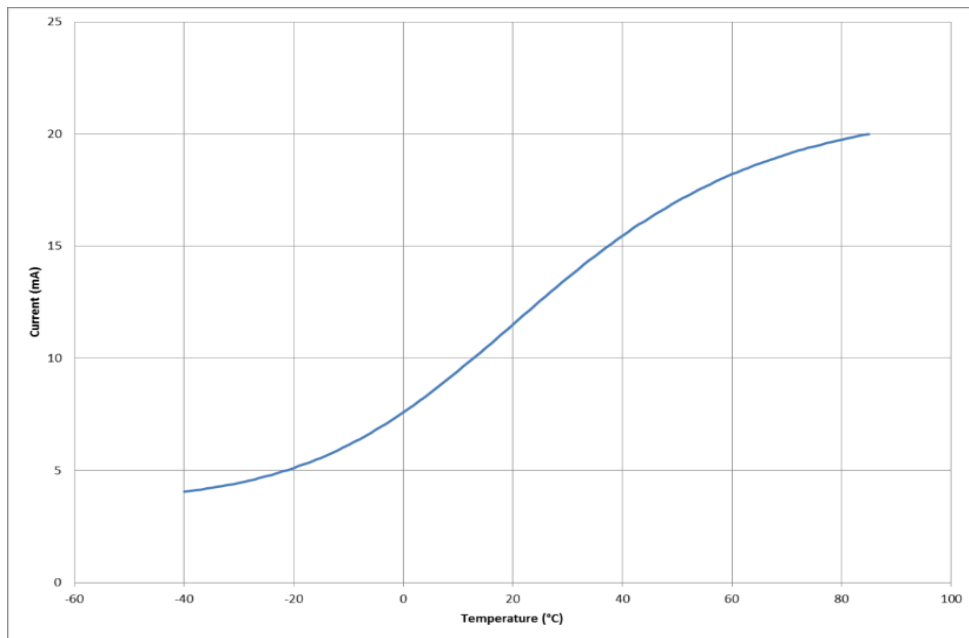

### Power Supply

Parameter	Test Condition	Min.	Typ.	Max.	Unit
Voltage		20	24	28	V <sub>DC</sub>
Current		20		80	mA

## DIMENSIONS

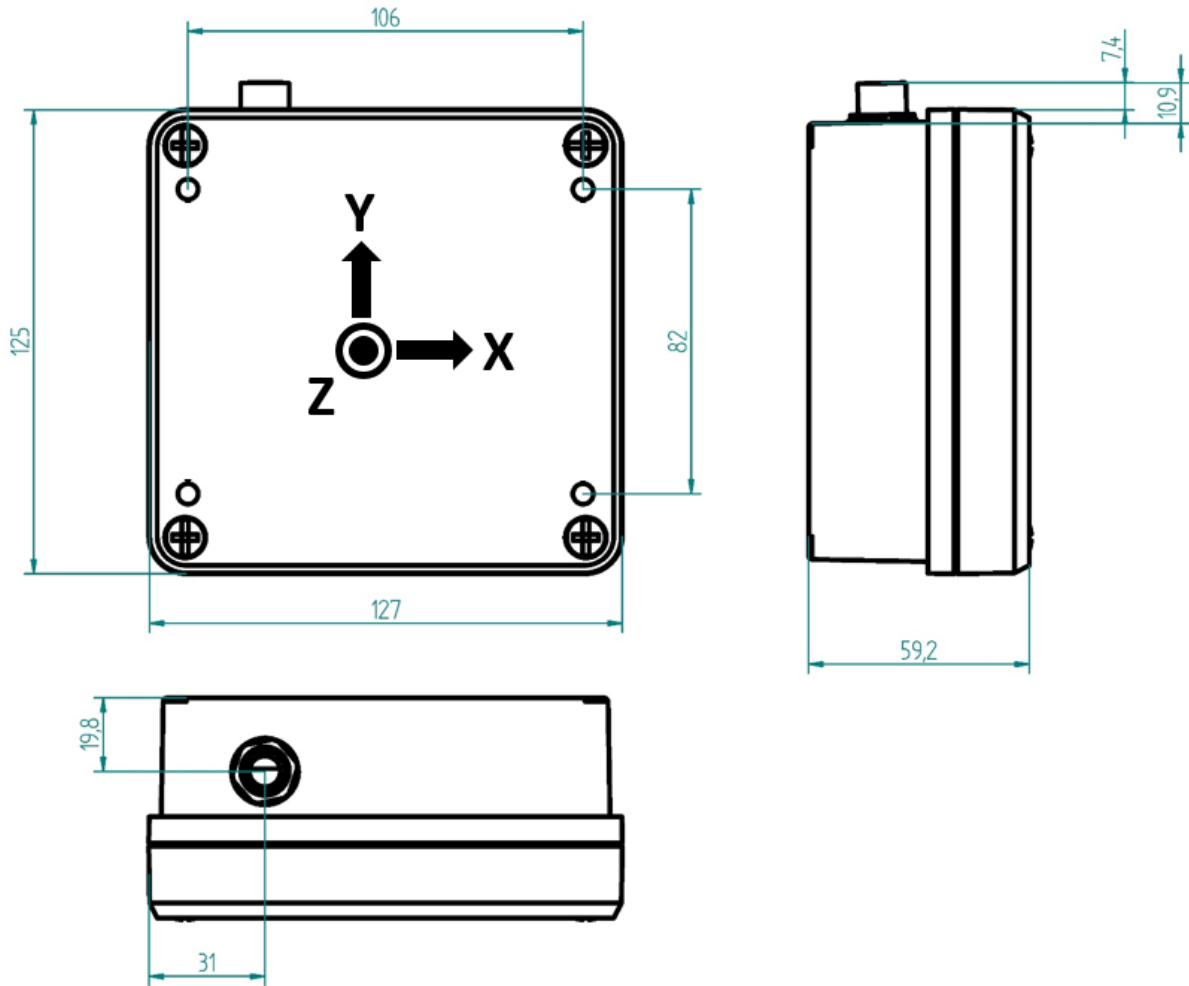

## REFERENCE DIRECTIONS

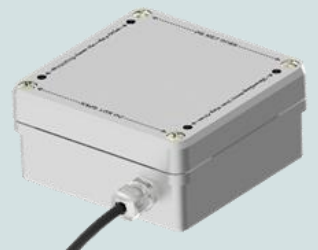
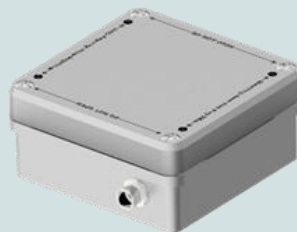
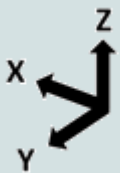

# RESPONSE

## Horizontal Mounting Model

GRAVITY



OUTPUT > 12mA



OUTPUT = 12mA

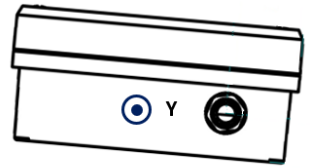

OUTPUT < 12mA

GRAVITY

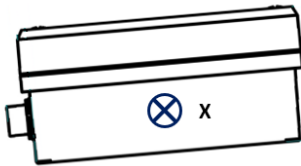

OUTPUT < 12mA

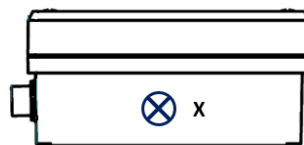

OUTPUT = 12mA

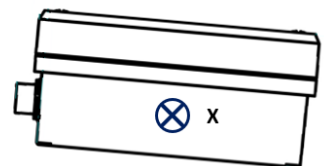

OUTPUT > 12mA

## Vertical Mounting Model

GRAVITY



OUTPUT > 12mA



OUTPUT = 12mA

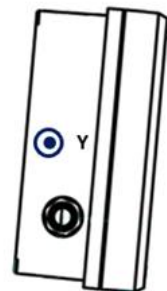

OUTPUT < 12mA

GRAVITY



OUTPUT < 12mA

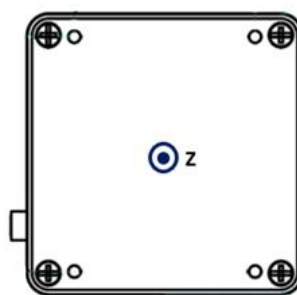

OUTPUT = 12mA

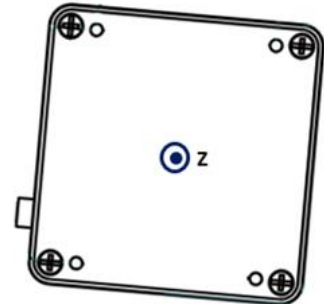

OUTPUT > 12mA

# CERTIFICATIONS

## Electromagnetic Compatibility

Standard	Limit / Level
<b>Emission</b>	
<b>EN 55011</b> Radiated Emission	30 MHz - 1 GHz Group 1 - Class A
<b>FCC 47 Part 15</b> Radiated Emission	30 MHz - 1 GHz Class A
<b>Immunity</b>	
<b>EN 61000-4-2</b> Electrostatic Immunity	4kV / contact 2, 4 & 8kV /air Criterion B
<b>EN 61000-4-3</b> Radiated, radio frequency, electromagnetic field immunity	80MHz - 1 GHz @ 10V/m 1.4 - 2GHz @ 3V/m 2 - 2.7GHz @ 1V/m @ 80% AM 1kHz
<b>EN 61000-4-4</b> Electrical fast transient / burst immunity	2kV - 100kHz on signal lines Criterion B
<b>EN 61000-4-6</b> Immunity to conducted disturbances, induced by radio-frequency fields	10V (150kHz-80 MHz) Criterion A
<b>EN 61000-4-8</b> Power frequency magnetic field immunity	Continuous field 30 A/m Short duration field 100 A/m 50 & 60Hz Criterion A

## Operating Temperature

Standard	Limit / Level
<b>IEC 60068-2-14</b> Change of Temperature	Cycling between -40°C and +85°C
<b>IEC 60068-2-1</b> Cold	Operation at -40°C (including cold start)
<b>IEC 60068-2-2</b> Dry Heat	Operation at 85°C

## ORDERING REFERENCE

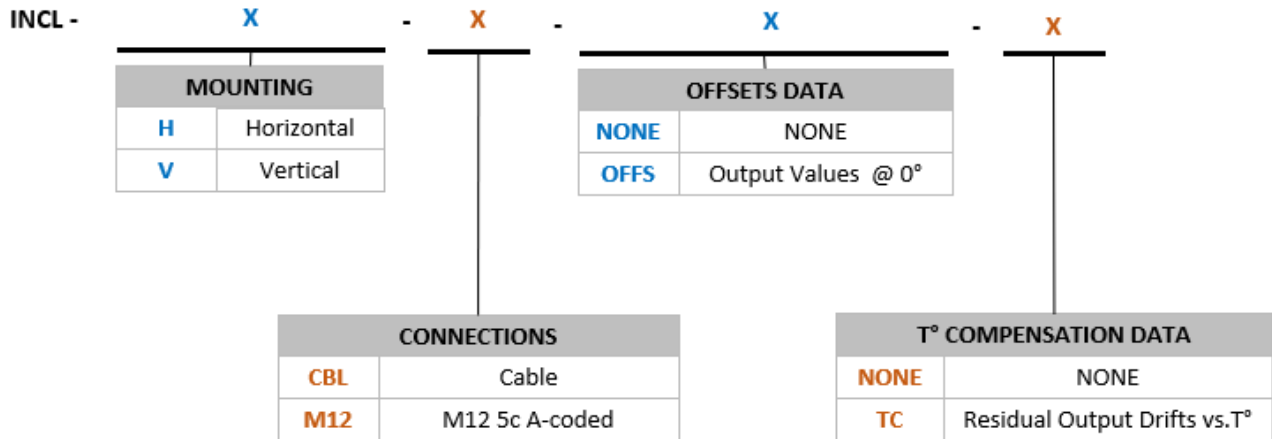

### EXAMPLE

INCL - V - M12 - OFFS - TC

### NOTE

- When ordering with cable connections, cable is mounted at the factory. Please specify required length.
- Standard cable gauge is 0.25 mm<sup>2</sup> (AWG24). Higher cable gauge might be required for long cable runs.
- Residual Output Drifts vs. T° are given for the range -10°C to +40°C by default

## ENGINEERING SERVICES

- Special coatings
- Special cables
- Integration with monitoring systems and cloud platform
- Adaptations for underwater use
- Adaptations for marine environment
- Other temperature range for residual output drifts vs. temperature